

**MOBILE CAMERA COMPUTER PROJECT BY EURO HI-TECH PHOTOGRAPHIC SERVICES LTD**

**ALL RIGHTS RESERVED (COPY RIGHT) ©**

**FULL MECHANIZATION & CUSTOMIZATION & MOBILITY OF THE COMPUTER.**

**STATE OF THE ART CAMERA MOBILE HANDSET DESIGN**

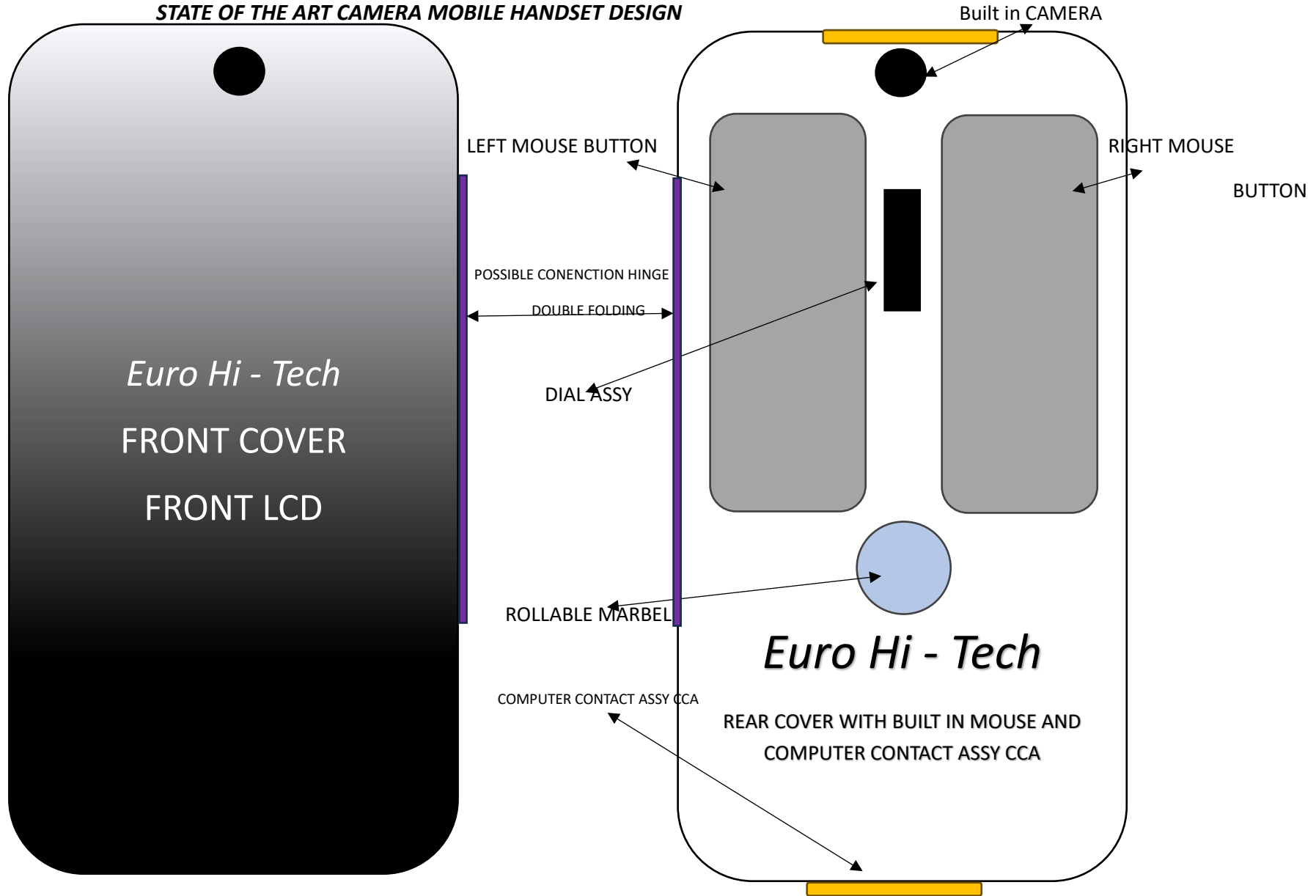

# STATE OF THE ART COMPUTER CAMERA DESIGN

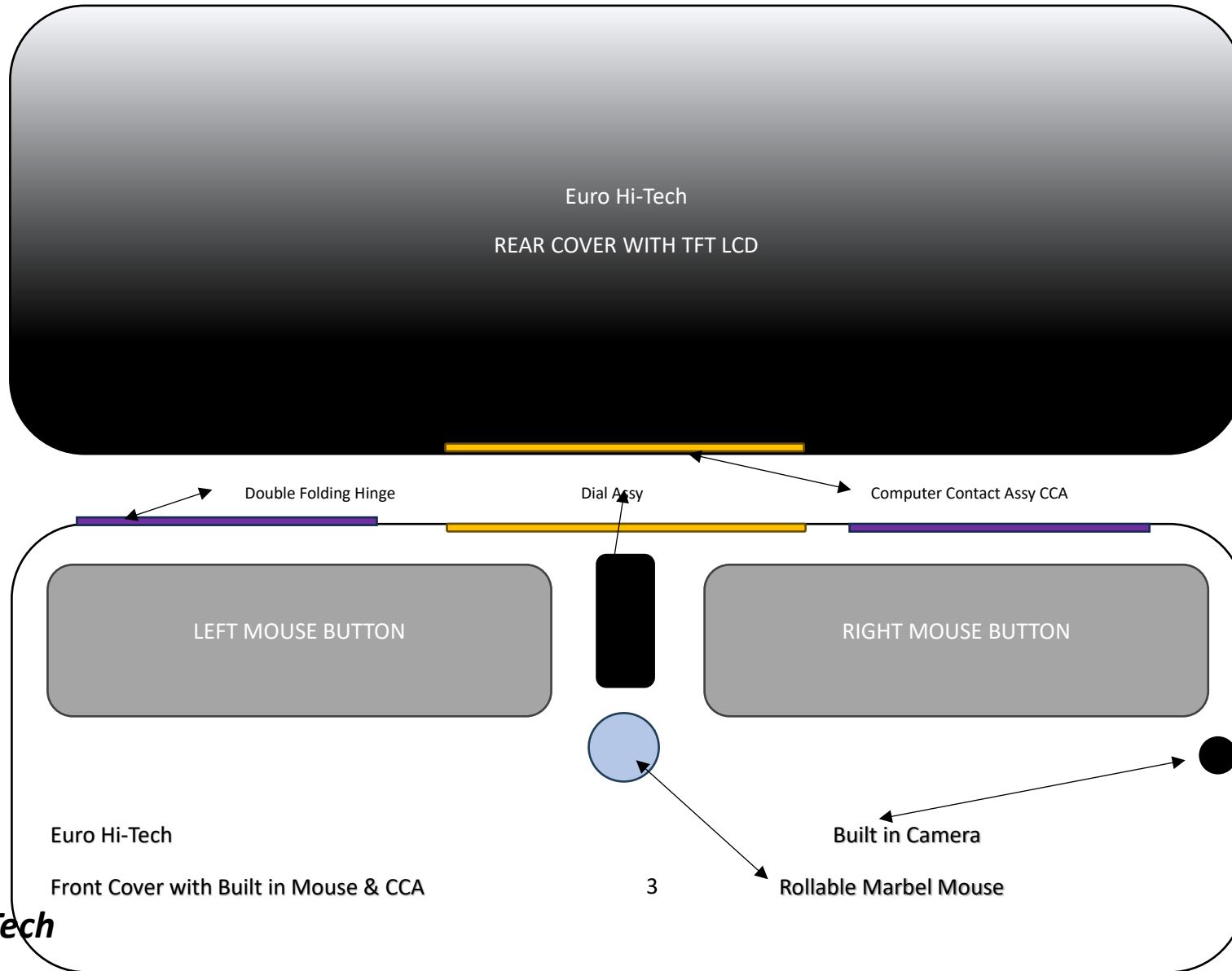

# PORTABLE CAMERA MOBILE COMPUTER

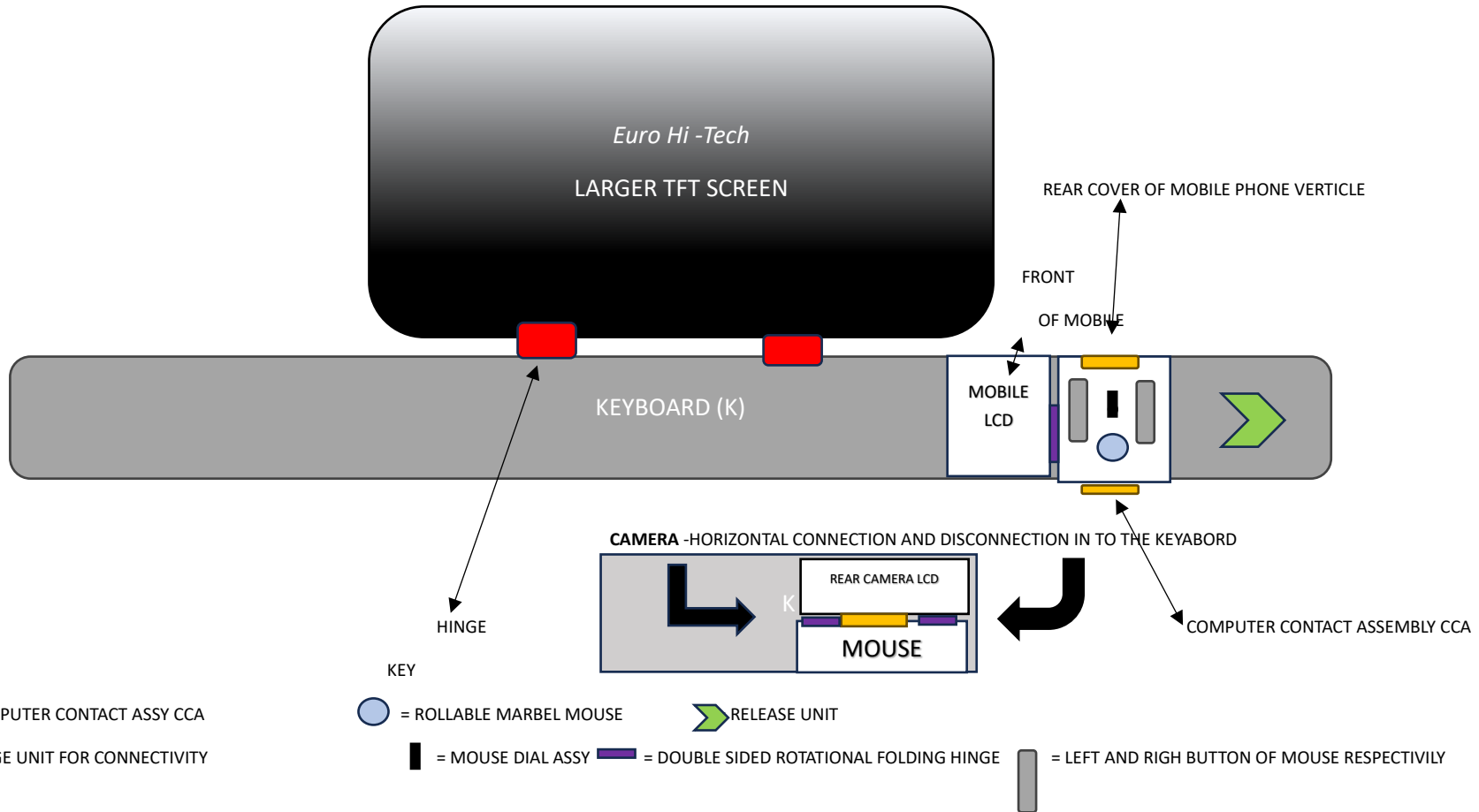

40 MOBILE CAMERA NETWORK OPERATION ON STANDALONE

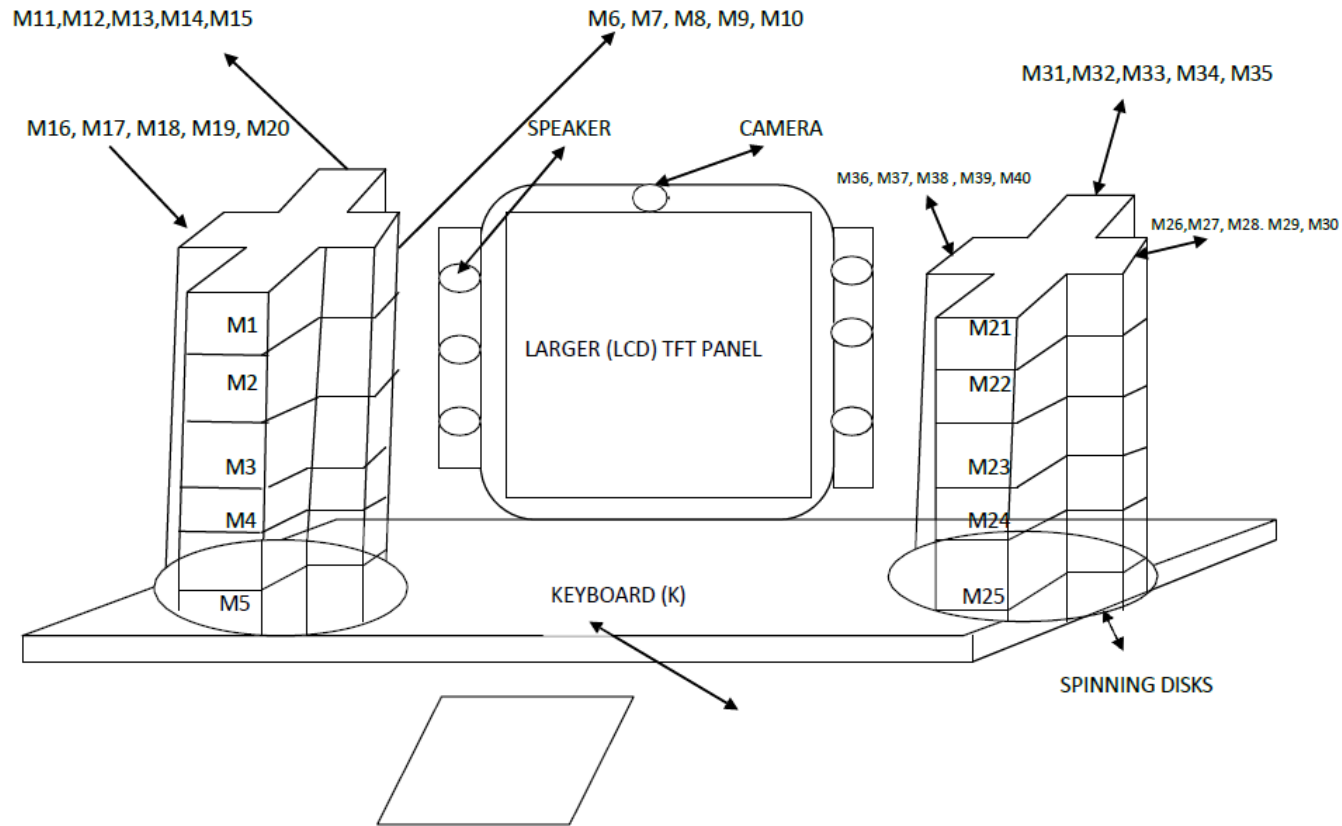

MOBILE CAMERA PHONE STACK DRIVE SYSTEMS, THIS TRACKS MONEY SUPPLY AND NEW  
CONCEPT OF MUSICAL SYSTEMS REMIX (MS) A- SECURITY CONCEPT.

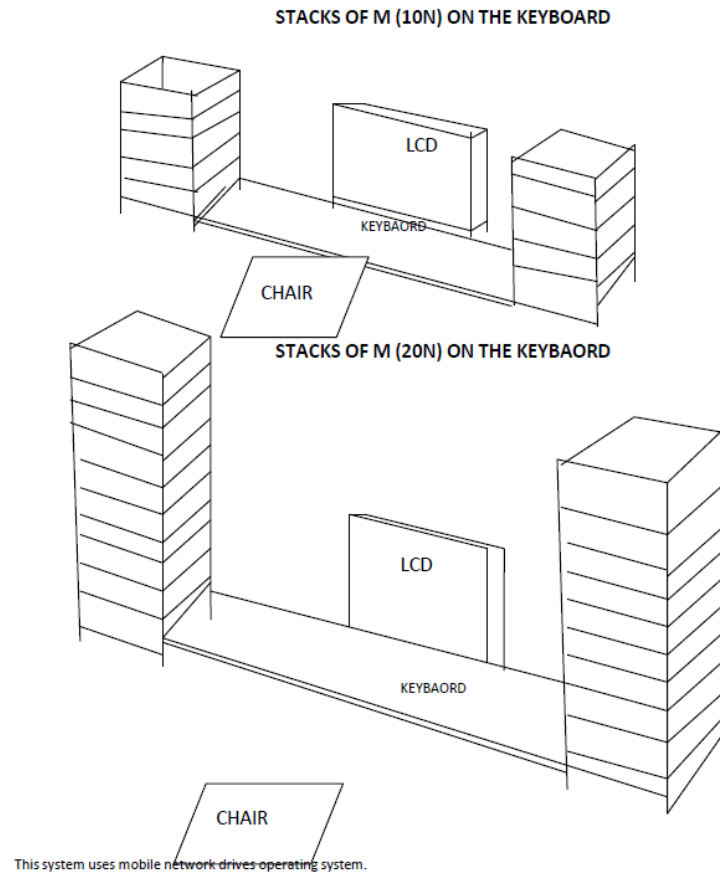

# TABLE TOP COMPUTER WITH BUILT IN TFT SCREEN/KEYBOARD AND CONNECTED AND DISCONNECTED MOBILE CAMERA PHONE

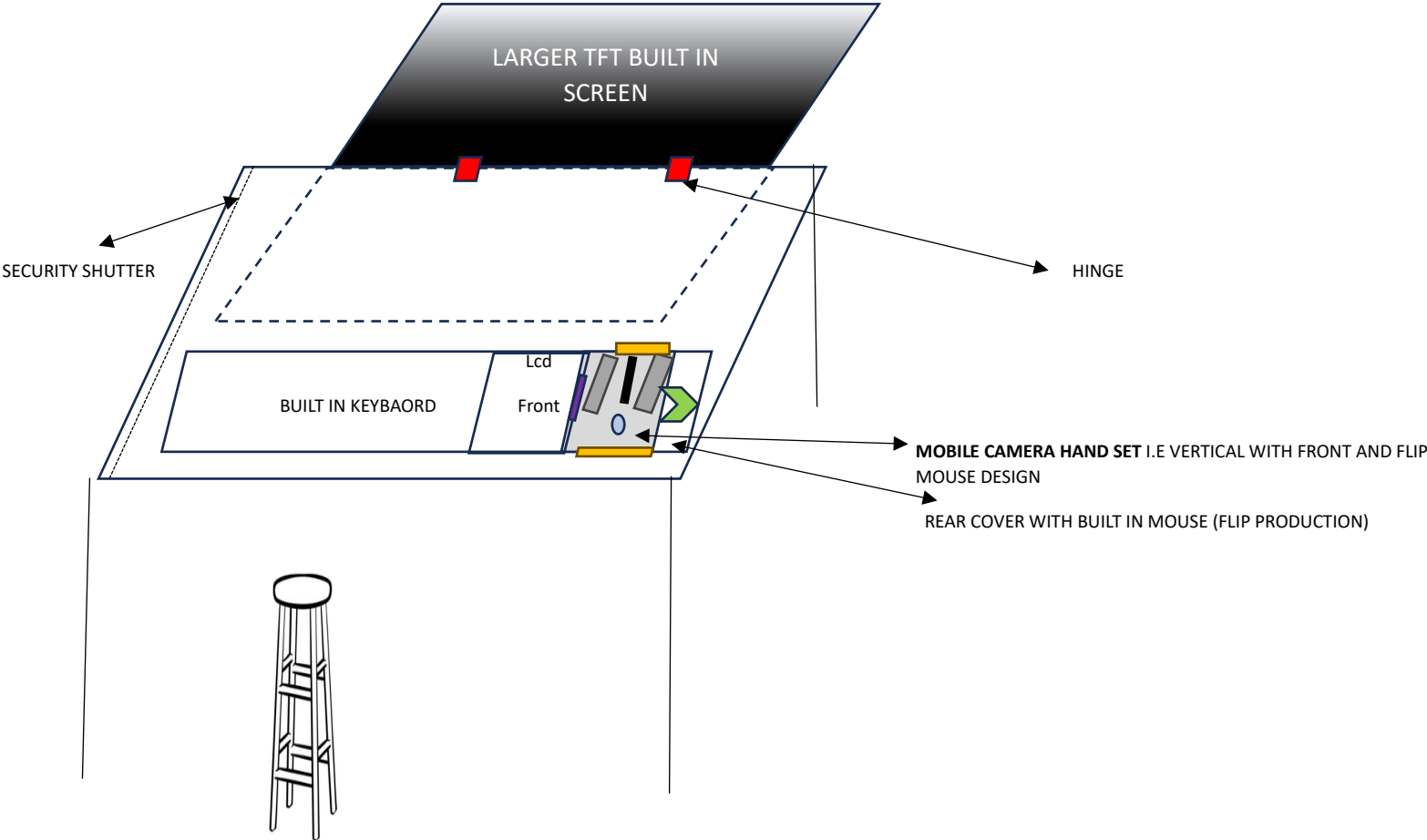

**SECURITY CONCEPTS OF N SQUARED TO INFINITY USERS- EXPANIONARY -WITH DUPLICATION OF HANDSETS**

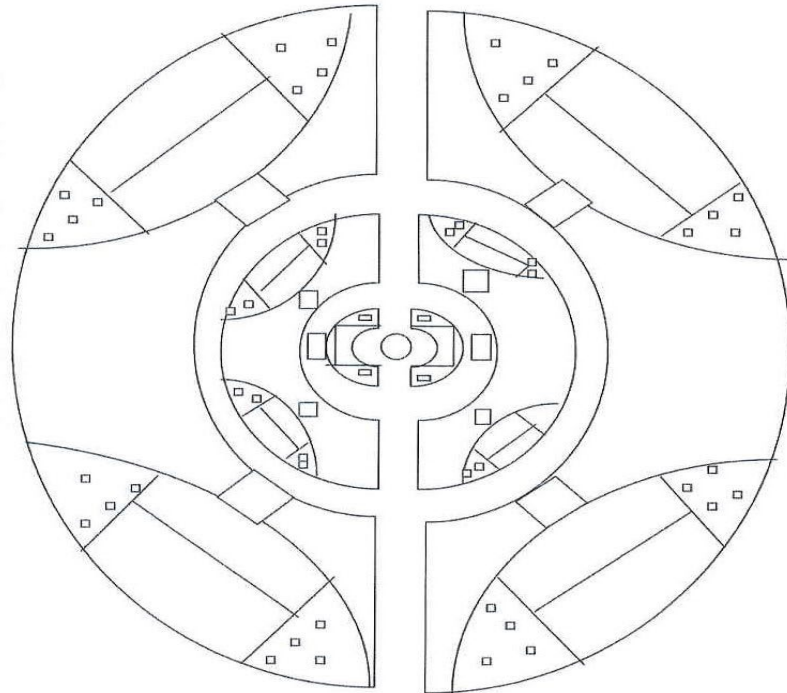



**EDUCATION CONTRACTS**

CICULAR HUB FOR DYNAMIC ELECTRONIC EFFECIENCY & SECURITY PLATFORM

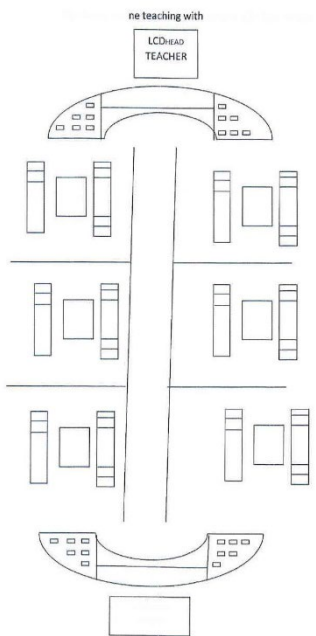
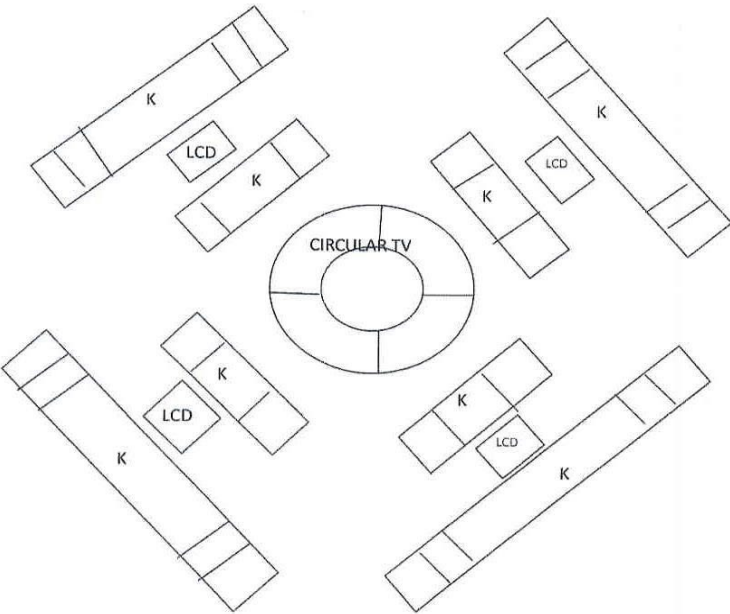

CYLINDER SCREEN 4 WAY SYSTEM WHICH CAN BE EXPANDED TO INTARMIN

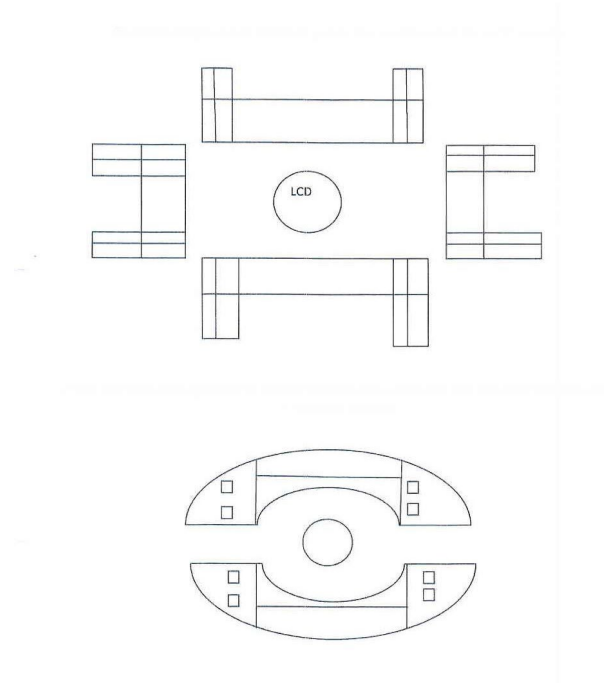

HETRONIAN SET UP N + 2 INCREASING TO INTARMIN

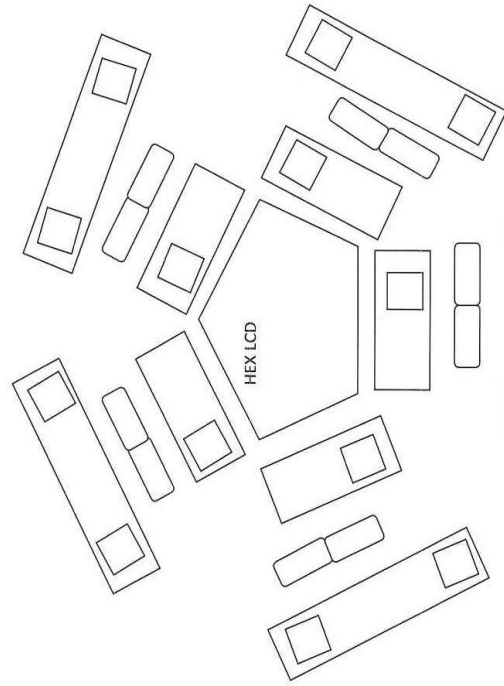

NETWORK PLUS (+) INFINITY DRIVES (N INCREASING BY N + 4 TO INIFINITY)

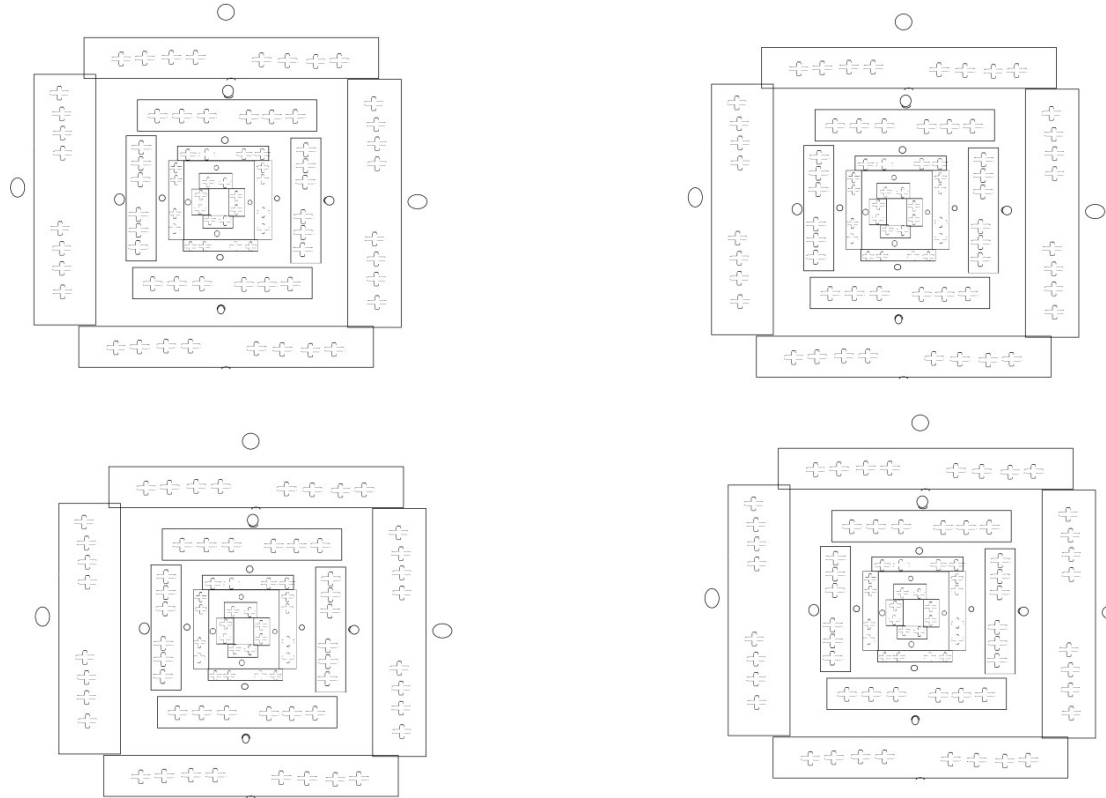

**TRIANGULAR DESK SET UP 3 WAY LCD SCREEN WHICH EXPANDS TO 2 + N USERS ON EACH KEYBOARD.**

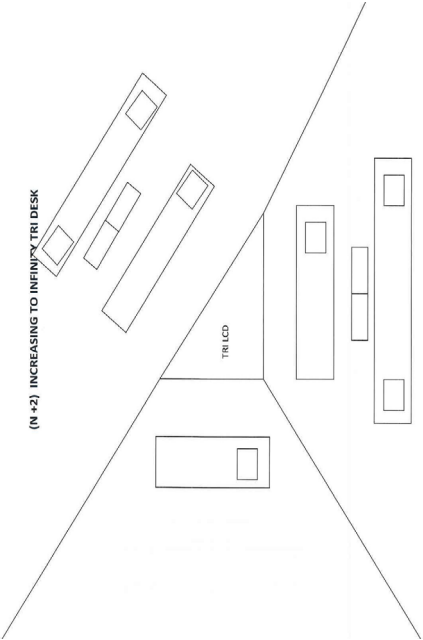

Firstly imagine a mobile phone or camera, well this can be docked in on to the keyboard. I.e a sleeping camera mobile on the right- or left-hand side of the keyboard. You can put a label/receipt printer on the keyboard or even a watch or even a calculator even a solar patch or newly designed broadband device with contact Assy. (no cables). This file will illustrate how this is done.

You effectively remove the central processing unit CPU, the personal computer is not required and a laptop becomes redundant.

Conversely the following pages will outline how to remove the USB ports, remove the Top Cover Flash Units, Remove the battery and No charger and even the memory cards.

It effectively illuminates the cable from the computer and camera mobile and simplifies it to an easy mobile camera computer which can be easily packaged up and sold to the consumer in every market in the world.

It uses five core principles which will be diagrammatically outlined below:

- 1) The use of Multiple flash units, built into the body of the camera.
- 2) The Use of Computer Contact Assemblies which removes the need for USB ports.
- 3) A Mobile Phone with Built-in mouse technique docked into the keys, which customizes and mechanizes the desktop computer to a beautiful system transferable all over the world.
- 4) On the standalone it's the principle of "what you see what you get twice".  
WYSIWYG
- 5) Autonomous Keyboard Vibration to recharge the camera mobile phone.

## ADVANTAGES:

So effectively you can have:

1. Autonomous Road/Bridge/Train Tracks built with minimal humans no sweated labour.
2. Autonomous house infrastructure building.
3. Plant meters with plants pots which indicate if water or light is required.
4. No more requirements of PC's and Laptops.
5. This system could lead to large government contracts around the world, where there is constant Wi-Fi outdoors and no need for Car Registration Plates, No Cards for driving License (E – License), Traffic Lights with Cameras and speedometers built in to them with quad lights, No Passports( E- Passports), diversion of flights away from civilian buildings, new type of camera multimedia messaging service and file transferability globally. No need for telecom towers and just one live operating system which throws out Wi-Fi constantly without disruptions. Also Automatic Ignition Start-ups and no need for keys as door locks can open with pass codes.  
Printers or Calculators built on and into the Keyboard via having computer contact Assemblies around the rim.
6. There could effectively be a transfer of data from the larger TFT to the Keyboard without a cable, just by using computer contact assemblies.
7. No Mouse
8. No Cables.
9. No USB Port which is replaced by contact assemblies.
10. No PC
11. No Lap Top.
12. The Mobile Camera Phone becomes the sole system to operate or operating system, which is then duplicated.
13. No Top Cover with now built in flash units in the body
14. No Charger No Battery because there is front solar panel and motion detection.
15. No Body Mount, No Rear Mount, No diaphragm
16. NO CMOS CCD
17. No shutter system?
18. No Telephoto or Wide angle Lenses
19. NO Memory cards or no sim cards
20. SOLAR REAR COVER WITH MULTIPLE FLASH SPOT UNITS
21. A different type of Main PCB or Infinity Processor.
22. The Hand Set Acts as the Operating System there after “save all information direct to handset”.

## Further ADVANTAGES:

### ADVANTAGES

There is No Desk Top PC effectively, you use the operating system from the mobile and duplicate the LCD image from there on the TFT monitor Screen.

Therefore low shipping costs, light weight.

Portable PCs you can take and use anywhere in the world with the mobile.

This will make file saving and sharing easier, allow you to save all PC file data on to the mobile.

You can manipulate and download various apps and use is symmetrically like a PC.

There are not many cables involved in developing this PC, only one which can also be used to charge the Mobile.

There may be no requirement of Main PCB with a No USB port as the data is being "reflected or mirrored" on to the larger TFT Monitor screen.

Perfect for various industries such as Education, Stadiums, Banking, Stock Exchange, Healthcare and Offices and domestic purpose. The education system can build the PC into the table and give each child a mobile which can then be used at home and at school etc.

In economics this will shift the Production Possibility Frontier (PPF) outwards of an economy due to use of technology.

This may alleviate Poverty in India and Africa and Brazil as many people can't

afford Wifi/Broadband due to poor connectivity. Therefore the use of Optimum Wifi on the mobile can make communication far greater. They can not afford conventional PC's either with Desktops which are complex to fit for them and difficult to use.

This can be built in different sizes and shapes with various colours, black, blue, red, green etc.

There will be no need for peripherals such as USB Stick or Memory Cards as all the data should be saved on the phone.

A network of PC's can be built in various shapes.

New innovation. The advantages appear to outweigh the disadvantages.

This design effectively customizes the desktop making it sleeker and more appealing to younger markets as its easier to assemble and use.

There is also effectively one gadget, one phone, one mobile, one DSLR, one compact camera operating as one Mono Device.

This computer has not been seen on EPOS systems or tills anywhere. In order to turn it in to a till just add a till machine at the

bottom of the computer, then retailers could use it, such as hairdressers and keep the tax records more efficiently.

This could make Land Lines Mobile and Transferable.

No tills. People can operate this small PC on a trolley on a intranet and scan the goods and debit from their phone and take the trolley straight to their car bypassing tills. Hence saving labour costs and adding to profit.

Pay direct on flight, bus, train. You do not need to pre-book via a travel agent, just check the time table and pay directly on flight, train or bus. Just dock your phone on the airline intranet and print out your ticket. No need for oyster cards.

This will drive human capital levels in IT and hence come before bio chipping people.

Cashless society. Less Cash Theft Crime.

Mopeds and motor bikes can have built in PCs so they can instantly track an order from their bike.

If its manufactured from Latest Solar panel material and motion detection technology there may be no mains or cables of plugs or 220v outlet.

Individuals can self document themselves and improve IT human capital levels, document and file. Very easy to do with scanning techniques.

This might be alternative to E-Passports and quicker and effective visa systems.

Reduce Stress, as people do not have to commute to work, therefore reducing traffic congestion and pollution.

Transform teleworking, people can work from home and turn in to a small service organization.

Can be fitted in Rear Seat of Cars, Rickshaws, Cycles, Tables, Chairs, Buses, Coaches, Flights and other Transportation hubs, U.S. Trains.

Could reduce crimes, by quicker information to the police and quicker preventions.

Improve information in Court Cases and Reduce Waiting Times in NHS and in General Service Providing groups.

Through economies of Scale this could reduce the price of the computer, hence make it affordable for all.

Make The operating System "live" like the internet?

Make the operating system work on batteries or without cables and power supply.

Wifi Towers Could be built

No more keys, as the passcode can be used to open door locks in homes and offices.

Automatic Shutters Opening and closing for retail shops on high streets on time daily.

No more 'on and 'off switch on the camera mobile.

This computer uses contact assemblies found on DSLR Cameras inside the mirror box which communicate with the lens to the body LCD.

Make the Land Line Mobile Globally.

No need for Mouse with a cable as this is built in to the mobile camera.

This is a computer which requires no cables no usb, no pc, and no laptop.

Can be easy to assemble from the customer point of view

Can be packaged and sold in the open market.

A duplication of mobiles can generate security.

Pay by Key

Artificial Ignition Start up and Stop  (Ctrl) ▾



**THE GAME CHANGER TO REMOVE THE USB CABLE AND SOCKETS WITH THIS HISTORIC COMMUNICATION METHOD OR SPARE PARTS.**

Below is what I am trying to discuss, it outlines communication of Data and Physical movement data i.e. to unlock and lock doors via the connection of two contacts.

The first one is exemplified in Figure 1. The External part of the lens contact assembly communicates with the external part of the DSLR Side body shown in Figure 2.

They both pose an internal make up, the lens side has the Main PCB henceforth the alteration of Main PCB in the mobile camera.

Perversely the DSLR internal circuit is made up of contacts circuit which connects into the DSLR Main PCB or Mirror box allowing effective movements of the mirror and AF data communication transfers on to the LCD for Display via the internal Main PCB. Thus no requirement of any Cables or USB Sockets, *only if the Camera Mobile is sleeping on the Keyboard with the built-in contact connections. Please note there will be a Flip Connection on the Camera.*

**FIGURE 1 LENS SIDE CONTACT ASSEMBLY EXTERNAL AND INTERNAL COMMUNICATION:**

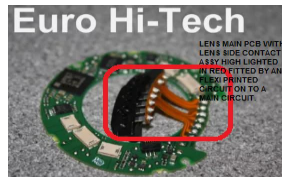

**INTERNAL**



**EXTERNAL**

**FIGURE 2. THIS IS THE BODY SIDE CONTACT ASSEMBLY, INTERNAL AND EXTERNAL COMMUNICATION WITH THE LENS WHICH DOES NOT REQUIR CABLE.**

**EXTERNAL**

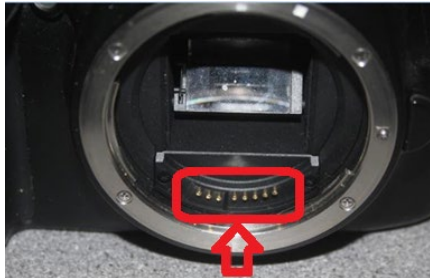

**THIS IS THE BODY SIDE CONTACT ASSEMBLY PART OF THE MIRROR BOX WHICH FUNCTIONS THE DSLR**

**Internal 35mm (8 PIN)**



So if the current market USB Cable or socket is replaced with the above type of communication referred to as “Computer Contact Assemblies” CCA vast computers can be built.

The keyboard is essential in this project as it has be redesigned but is pretty cheap in the market place.

All data will be saved directly on the mobile camera via the systems I mentioned earlier. Such as the Twin display (WHAY YOU SEE IS WHAT YOU GET TWICE, WYSIWYGT) from Camera Mobile to the Larger TFT Screen when camera mobile is sleeping on the keyboard with computer contact assembly built in them and in the internal DSLR Contact assembly built in to the key board. (Flick the Contact Flex into the Internal Keyboard)

The Service Costs will predominantly be a fault in the communication of the Computer Contact Assemblies it could be minimal compared to the masses of connectivity faults with the cable and USB Socket via misuse and tethering.

So effectively once built you will get a New Type of Computer where data is taken all over the world, like page 4.

#### ***E GAME CHANGING CONTACT ASSEMBLY***

Below is a sample of the contact assembly which just needs to be reshaped straight and attached to the right and left side of the mobile or camera phone or top and bottom. This will effectively lead to turning the camera or mobile phone into a very smart computer.



Prototype of the Gold Contact Assembly.

BOTTOM

TOP

35mm

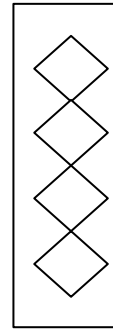
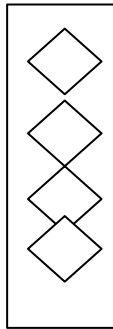

# ***Euro Hi-Tech Innova ©***

EURO HI-TECH PHOTOGRAPHIC SERVICES LTD

If one horizontal long row on contact assembly on the base of the camera phone does not work, then may be a row of two or more contact assemblies can be used to transfer data.

I.e. Transfer data from the camera mobile phone LCD Display to the Upper TFT Screen via Flexible Cables/Printed Circuit via the hinge and display what you see is what you get twice by using the mobile phone as the operating system.

This has no Personal Computer no CPU and No Lap Top and Separate Land Lin e Phone, it s all built in. This is effectively a new concept type of powerful computer using one or more database gadgets like a camera mobile phone. This can be forecasted to control Global Money Supply via New ATM Computer Systems.

Even Banks don't use this type of machine, it very novel and interesting to say the least.

TOP of Camera Mobile Phone



Bottom of Camera Mobile Phone.



X 4 Good Computer Contact Assembly Connectivity.

File date:04/11/14

**TWIN FLASH & QUAD FLASH & MULTIPLE**

**FLASH UNITS**

TWIN FLASH

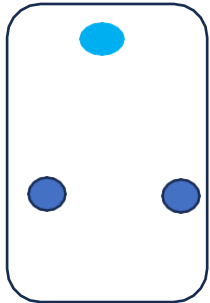

KEY:  OPTICS/LENS

FLASH UNITS



**TWO FLASH UNITS BUILT IN TO THE CAMERA BODY ABOVE ON A CAMERA TO ENHANCE NIGHT/DENTAL PHOTOGRAPHY AND WHICH CAN ALSO BE USED AS ADDITIONAL LIGHTING SUCH AS A TORCH**

QUAD FLASH UNIT

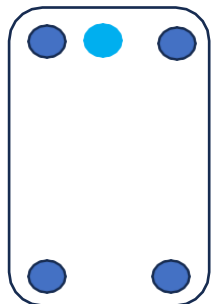

**QUAD FLASH UNIT WHERE THERE ARE FOUR FLASH UNITS BUILT INTO THE BODY OF THE FRONT COVER OF THE COMPACT CAMERA OR DSLR OR MIRRORLESS CAMERA, HELPS TO INCREASE QUALITY OF LIGHT IN NIGHT TIME.**

## ***Euro Hi-Tech Innova ©***

IN DSLR OR MIRRORLESS CAMERAS THERE IS EFFECTIVELY NO TOP COVER AND NO VIEWFINDER UNITS NO HOT SHOE NO SUPER IMPOSE PLATE AND NO PENTAPRISM AND NO FOCUSING SCREEN.

HAVING MORE THEN ONE FLASH UNIT BUILT IN TO THE BODY OF THE CAMERA ALSO REDUCES THE NEED FOR A SPEEDLITE FLASH GUN. THEREFORE, CUTTING THE *SERVICE AND REPAIR COST* OF CONTINUAL DEFECTS IN THE HOT SHOE WHERE BY THE HOT SHOE ASSEMBLY SNAPPS AND HOT SHOE BECOMES LOOSE. NO HOT SHOE UNIT. NO TOP LCD WINDOW, NO BUTTONS ON TOP COVER UNIT.

ALSO CUTS THE TIME IN CLEANING OR REPLACING SCUFFED FOCUSING SCREENS.

ALSO HAVING A TOP COVER PRODUCES DEFECTS SUCH AS THE ERROR 05 OR FLASH POP UP FAILURE. THUS THIS BUILT IN SYSTEM CUTS THE DEFECT RATE AND *SERVICE & REPAIR COST* IN REPARING/REPLACING THE TOP COVER UNIT.

IT ALSO MAKES THE CAMERA APPEAR TO LOOK SLEEKER AND FUN LOVING TO USE. NO HAND GRIP. ALL THESE SYSTEMS TURN THE CAMERA IN TO A COMPUTER HANDSET.

## ***Euro Hi-Tech Innova ©***

### **REAL TIME SERVICE & SUPPORT -ALPHABETICAL & STRUCTURAL INVESTMENT IN OFFICE SHAPES.**

#### **HOW TO ACHIVE OPTIMUM EFFICIENT REPAIR FACILITY BY CHANGING THE STRUCTURAL SHAPE OF THE ORIGINAL OFFICE DESIGN**

##### The conditions:

- 1) You need good work flow i.e at least 75 units per week for repair. Maybe multiple multinational contracts would be nice.
- 2) You have to have minimum SME with 1-5 or 1-10 employees
- 3) You need to accommodate for the ultra-computer designs outline previously as well as have a RMS in position. Such as a Repair Management Software (RMS) like AYS Software, web based.
- 4) Colored Lin Bins with Organic Locations in different sizes.
- 5) A department of Booking Repairs who can see empty bin locations and Department for Quality Control maybe required.
- 6) A Row of Tools next to the shape would be ideal.



# Euro Hi-Tech Innova ©

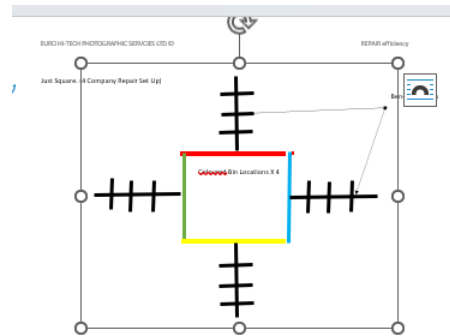
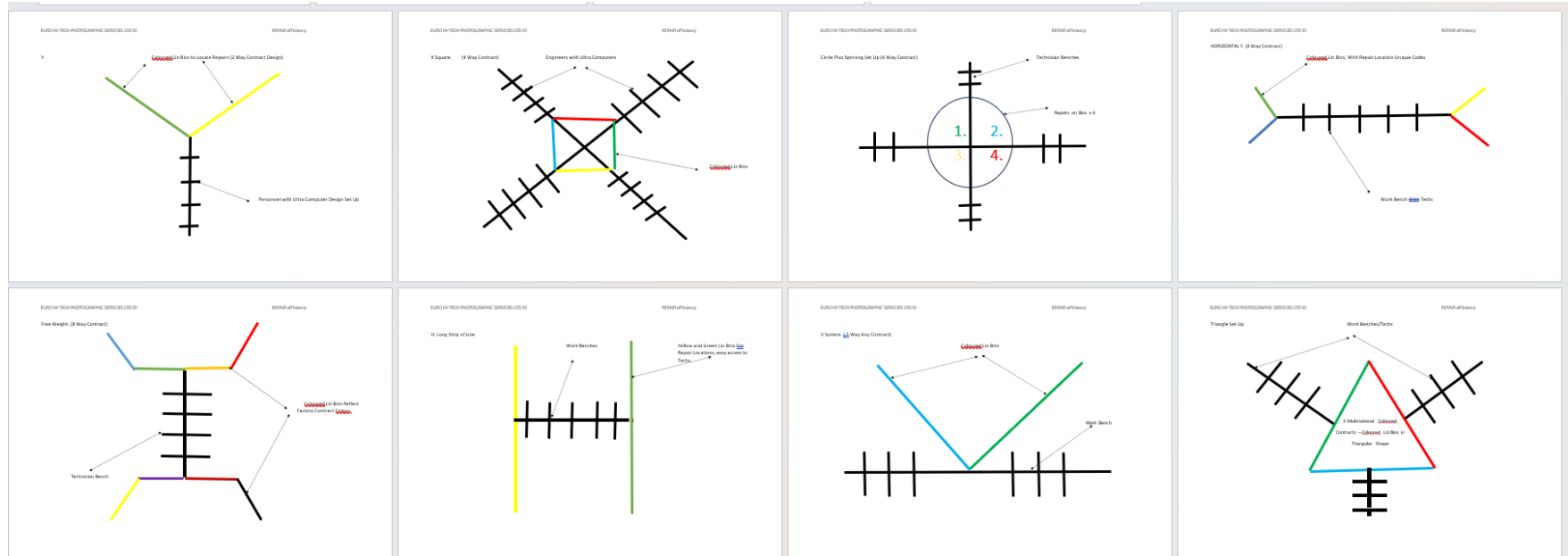

## ***Euro Hi-Tech Innova ©***

### DISADVANTAGES:

- 1) Companies Can pull out of Contracts Any Time.
- 2) Techs Leave Bins which are awaiting spares lying around nearby their area, wasting space.
- 3) Bin Sizes Could be too small once spare parts are put in to bins as well as the products.
- 4) Cost of Land/Area Might not make it practical
- 5) Spare Parts could fall on the floor and loose online Tracking
- 6) A Bin Located may be required.
- 7) Not enough space or not enough bins might become an issue for more work.

## ***Euro Hi-Tech Innova ©***

**FIGURE 1. IMAGE OF THE DIAL ASSEMBLY used as Scroller UP & DOWN**



This can be used to scroll up and down the images when the mobile is connected or disconnected on or off the keyboard. This is located on the reverse/rear of the mobile camera phone or on the Front Cover of the Camera at the Top in the middle.

## ***Euro Hi-Tech Innova ©***

**FIGURE 2. IMAGE OF THE MULTICONTROLLER JOY STICK/MARBLE**



These Mult controller joy sticks are found commonly on EOS 5D MARK III they are used to scroll all around the LCD and make selections from menu options and selection made when depressed. They are on the Rear Cover of the DSLR Camera. This would be located on the rear/Back of the mobile camera phone on the top middle, in-between the Right- and Left-Hand Mouse Buttons respectively. Or located on the Front Cover Top Middle if applying to the horizontal camera.

Also, a Marble (Round ball) Could be used in replacement of this for more effective cursor locations.

A double cursor on the standalone would look nice, but one cursor should do the service for multiple mobiles and having one master phone on the right or left of the keyboard on the base.

**NEW CONCEPT COMPUTER MOBILE WITH BUILT IN MOUSE SYSTEM-INFINITUDE IN1Y**

Here we have the option of putting the mouse on to the mobile phone. It consists of left- and right-hand button at the base of the phone. With a Dial Assembly to scroll up and down with on the page and a multicontroller joy stick or a rollable mouse to search the page with a cursor.

This is then docked or slept on to the keyboard without the built in mouse buttons with simply the contact assembly on the base of the phone as well designed on the mid keyboard.

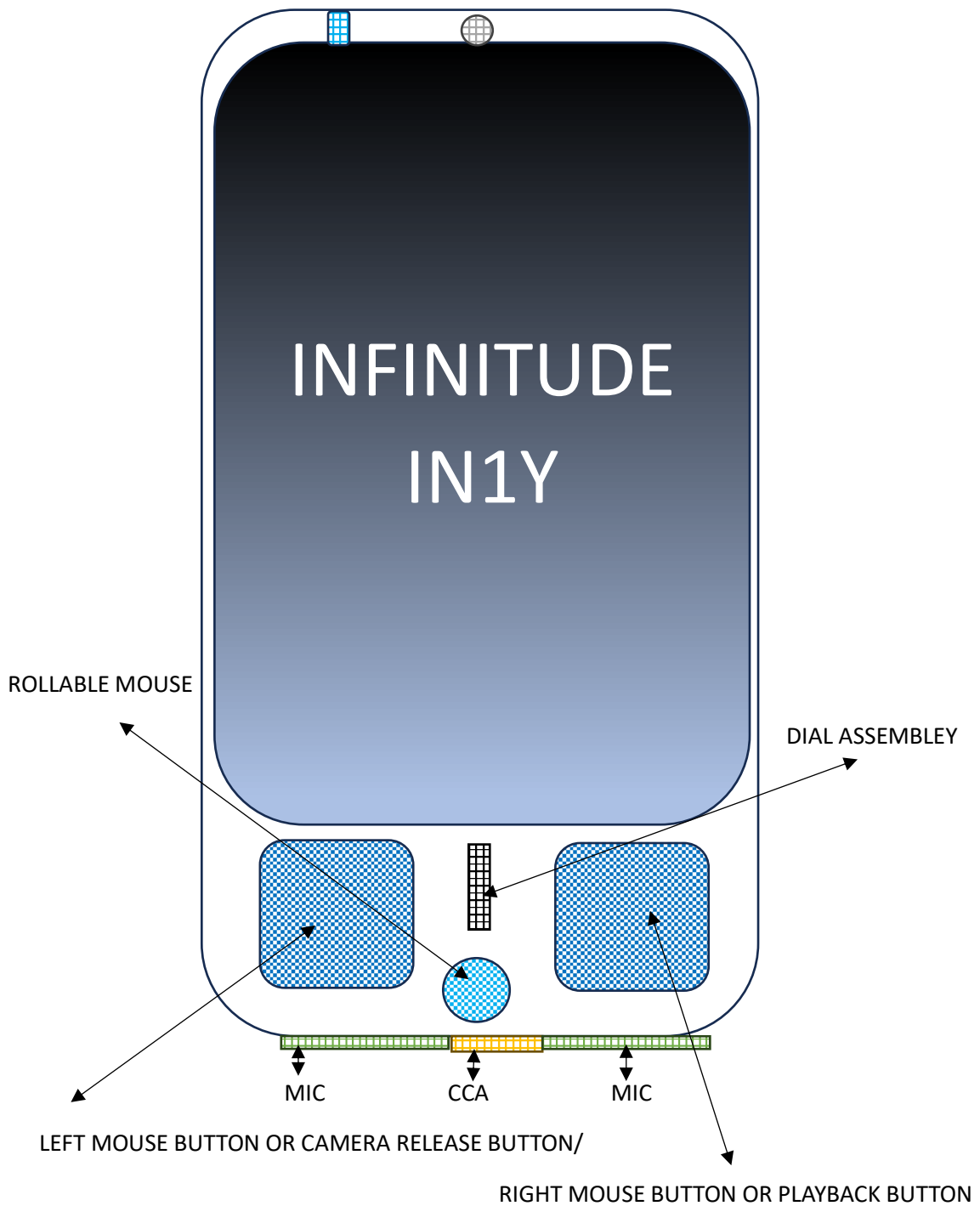

# Ubiquity U2Y

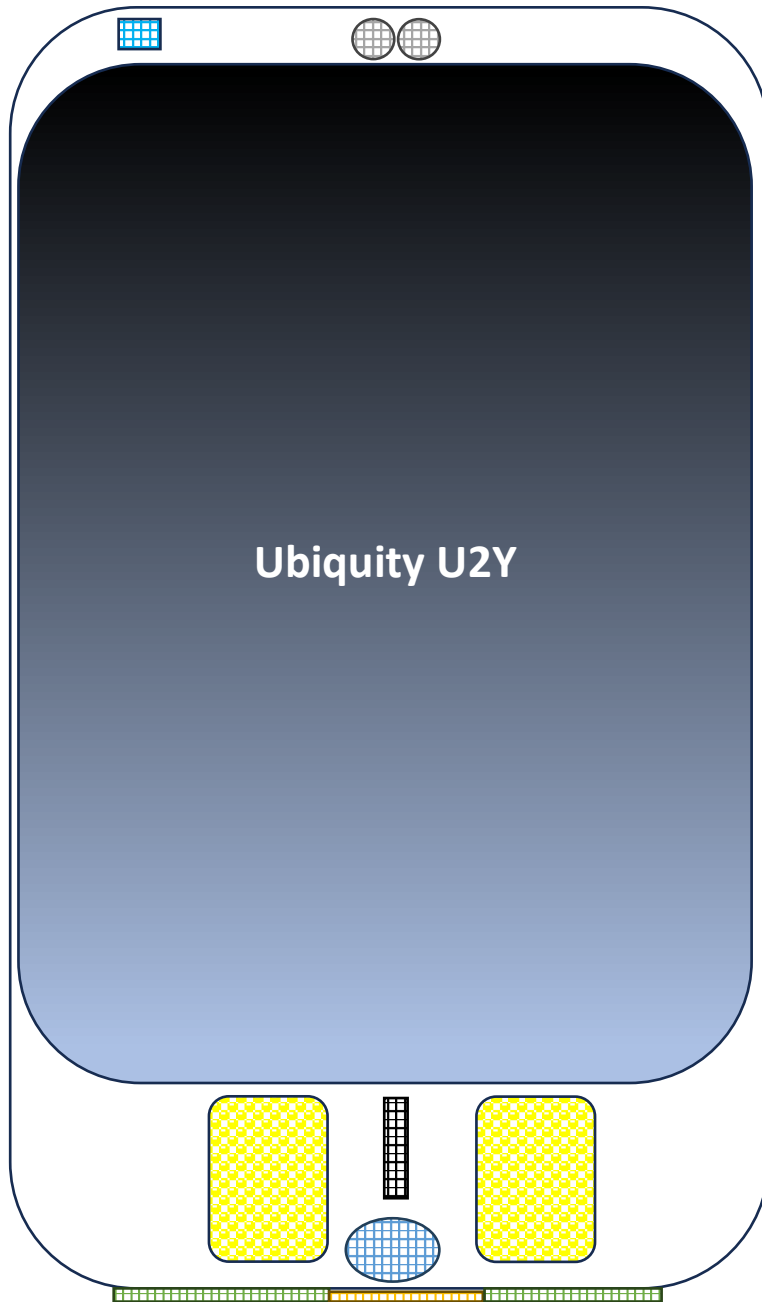

# Future 3y



## ***SIMPLE KEYBOARD DESIGN FOR LIVE OPERATING SYSTEM***

You get a live operating system once all three products are connected down on to the keyboard simultaneously.

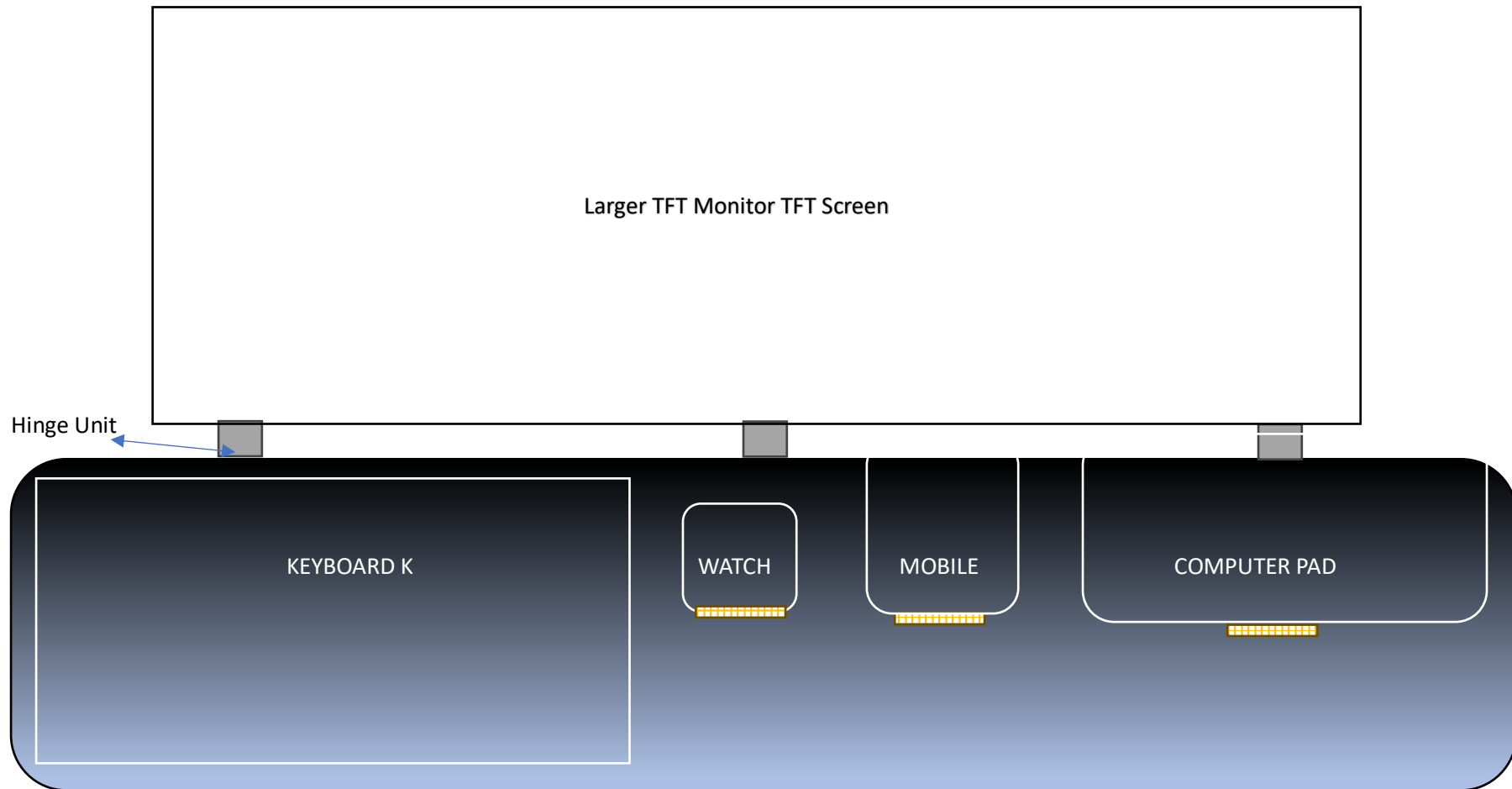

KEY: CCA 



## BLISS BMCPM1Y

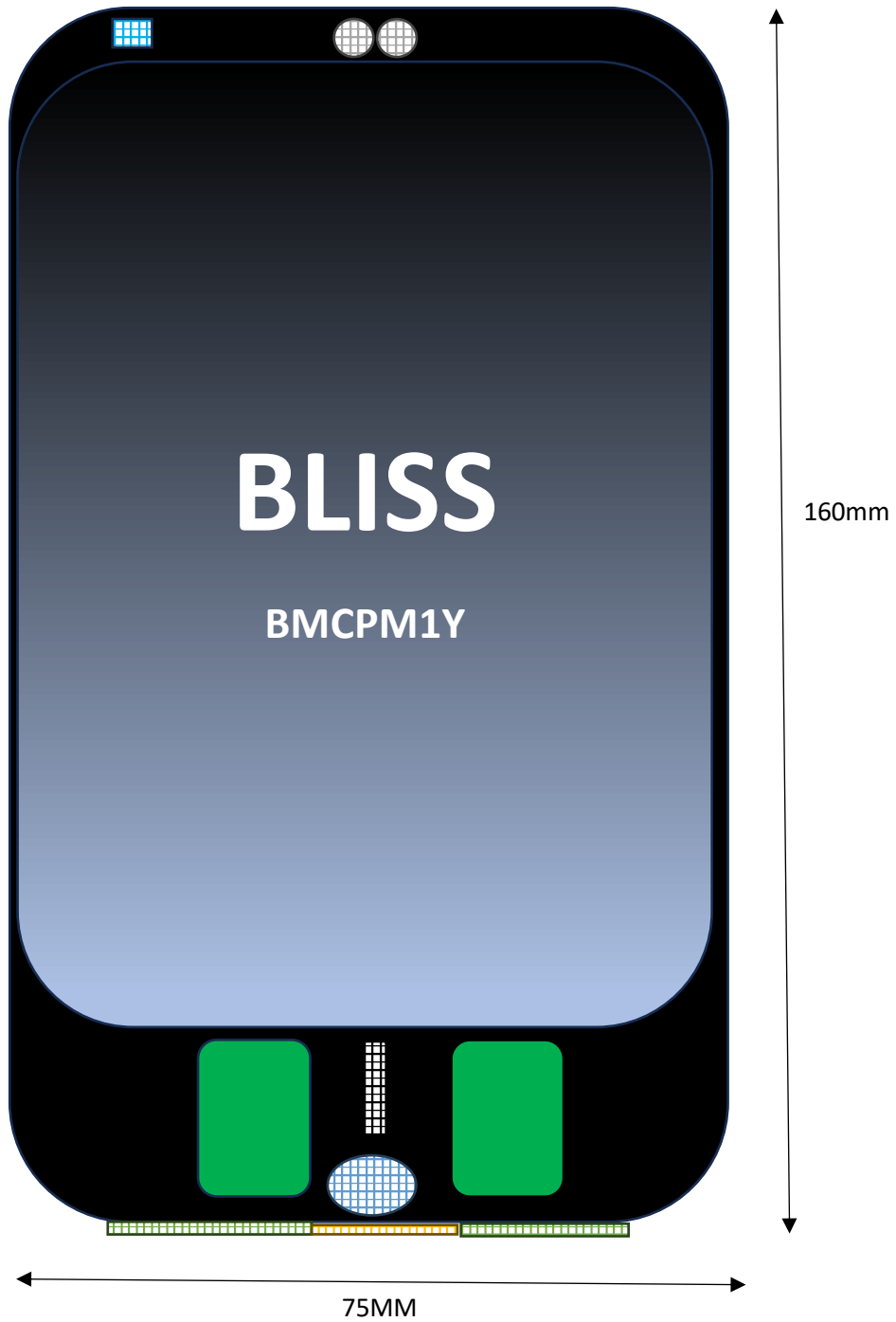

## SEDUCTIVE SMCPM2Y



## EXCELLENT EMCPM3Y

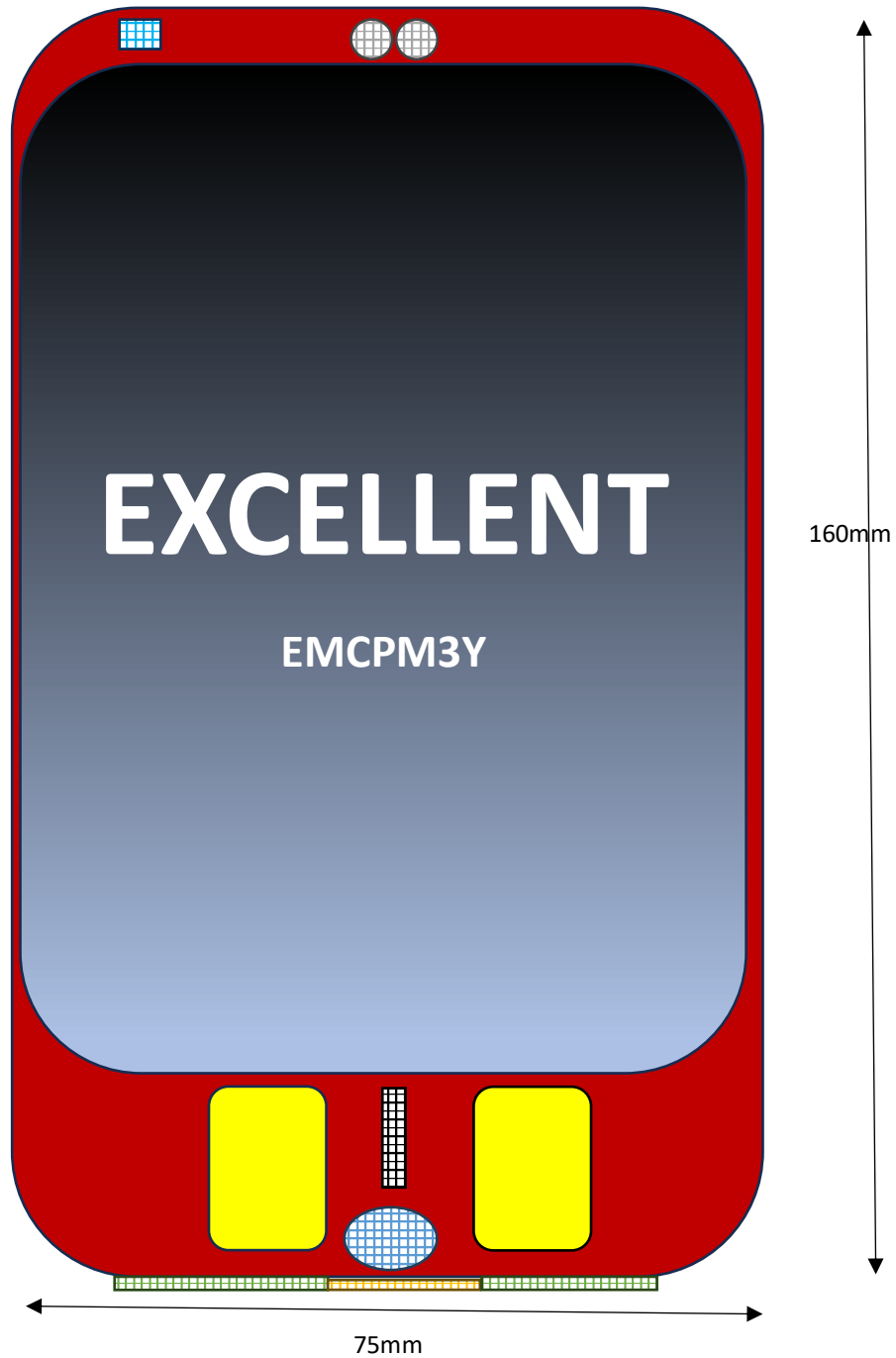

## ALTERNATIVE OPTION OF CAMERA MOBILE COMPUTER WITH USB ON TOP

Here there is NO CPU and no Lap top. This could be one form of design.

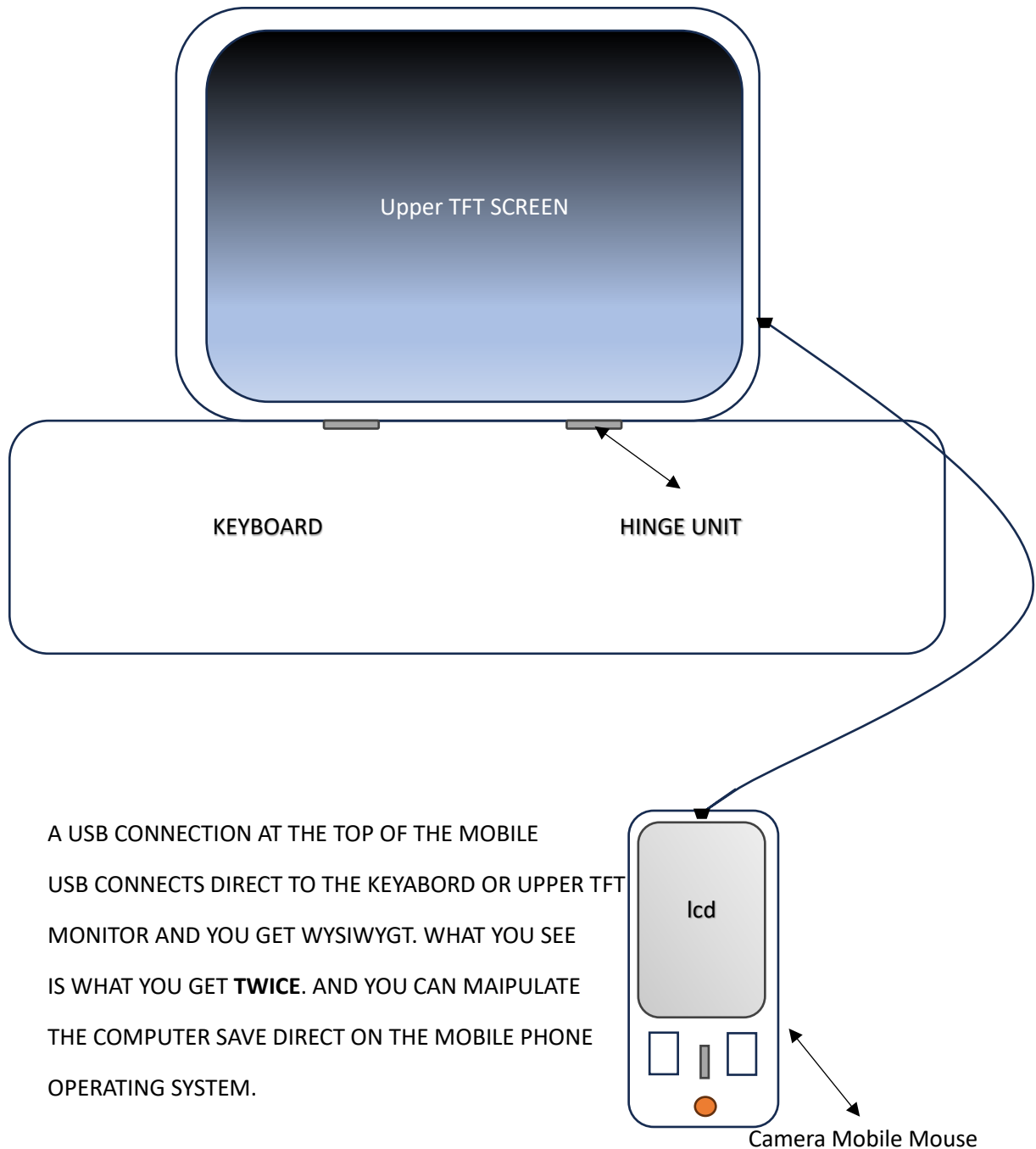

A USB CONNECTION AT THE TOP OF THE MOBILE  
USB CONNECTS DIRECT TO THE KEYABORD OR UPPER TFT  
MONITOR AND YOU GET WYSIWYGT. WHAT YOU SEE  
IS WHAT YOU GET **TWICE**. AND YOU CAN MAIPULATE  
THE COMPUTER SAVE DIRECT ON THE MOBILE PHONE  
OPERATING SYSTEM.

But hen again this is with the cable and USB, the whole of my exercise is to remove the USB via  
Computer Contact Assy and remove the cables from the computer to make it more efficient and  
portable. It would be difficult to network this with stack systems and N Plus Network Drives.

**The concept of Camera Mobile Phone Eject Cassette Mech Computer**

1. On the rear of the DSLR Camera you can build a mobile phone cassette deck eject mechanism where you slot the mobile in to the rear of the camera where there are no more LCD built into the DSLR camera. The cassette eject mobile phone LCD on the rear of the DSLR acts as LCD and thus docks into the key board via contact Assy around the rim in to the keyboard.

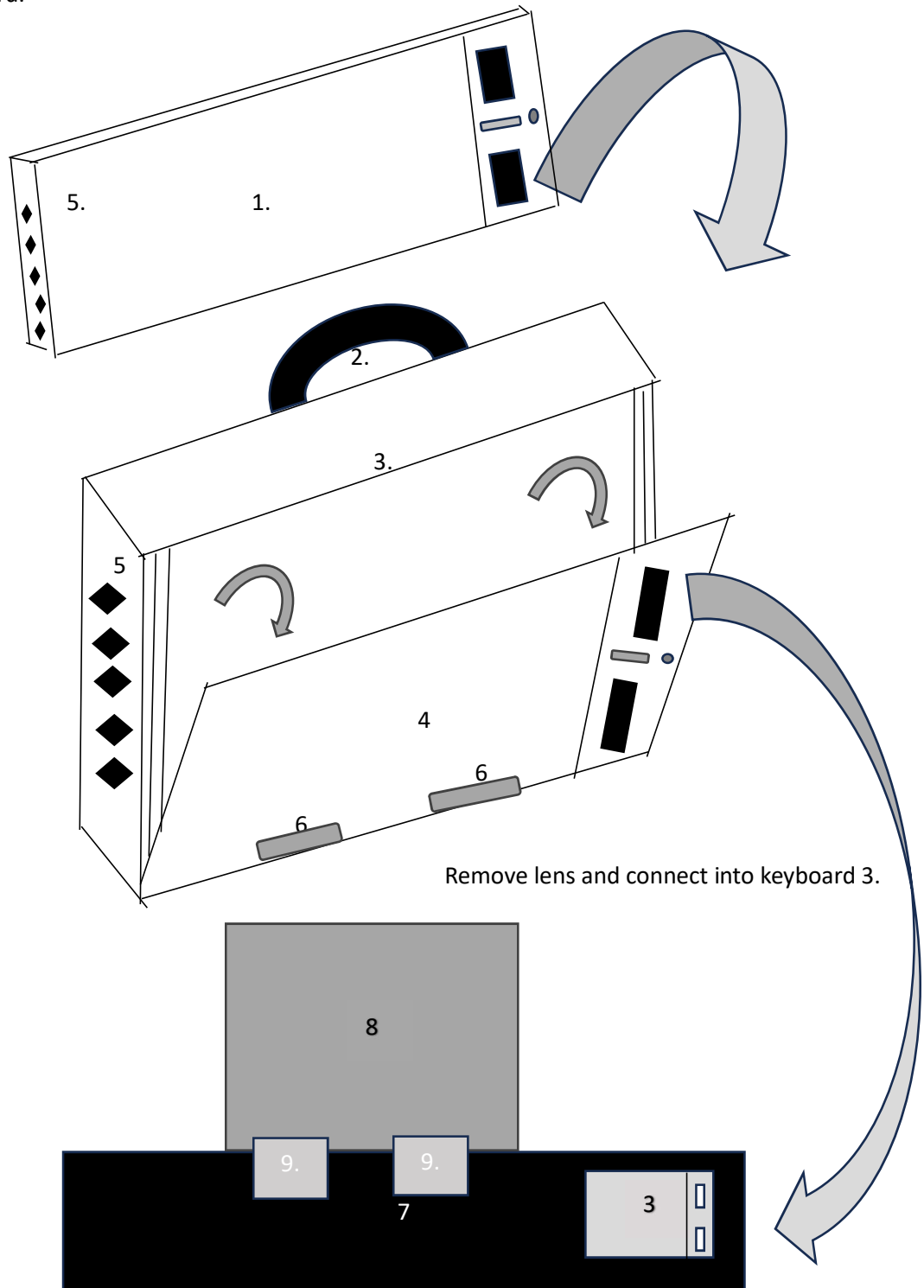

KEY.

1. CAMERA DSLR WITH LENS
2. FRONT LENS UNIT
3. MAJOR CAMERA BODY
4. REAR OF MAJOR CAMERA BODY THE EJECT SYSTEM
5. COMPUTER CONTACT ASSEMBLIES
6. HINGE UNIT OMN THE BASE OF THE REAR DSLR CAMERA
7. KEYBOARD
8. LARGER TFT SCREEN
9. HINGE UNIT CONNECTION FROM LARGER TFT TO KEYBAORD MAKING IT VERSATILE.

## THE VHS MOBILE MASTER CAMERA PHONE EJECT MECH SYSTEM COMPUTER.

Here we have the master mobile camera phone built into the middle of the keyboard which connects and disconnects like a VHS entering a video system, the keyboard is slightly more top to bottom longer. You can have more than one master phone built into the keyboard like a VHS video mechanism system. You can add a built-in Tilt under the keyboard and make it globally versatile. Or you can have **Stack Mobile Camera Phone Keyboards** one on top of each other with eject and insert mechanisms for camera mobile camera,

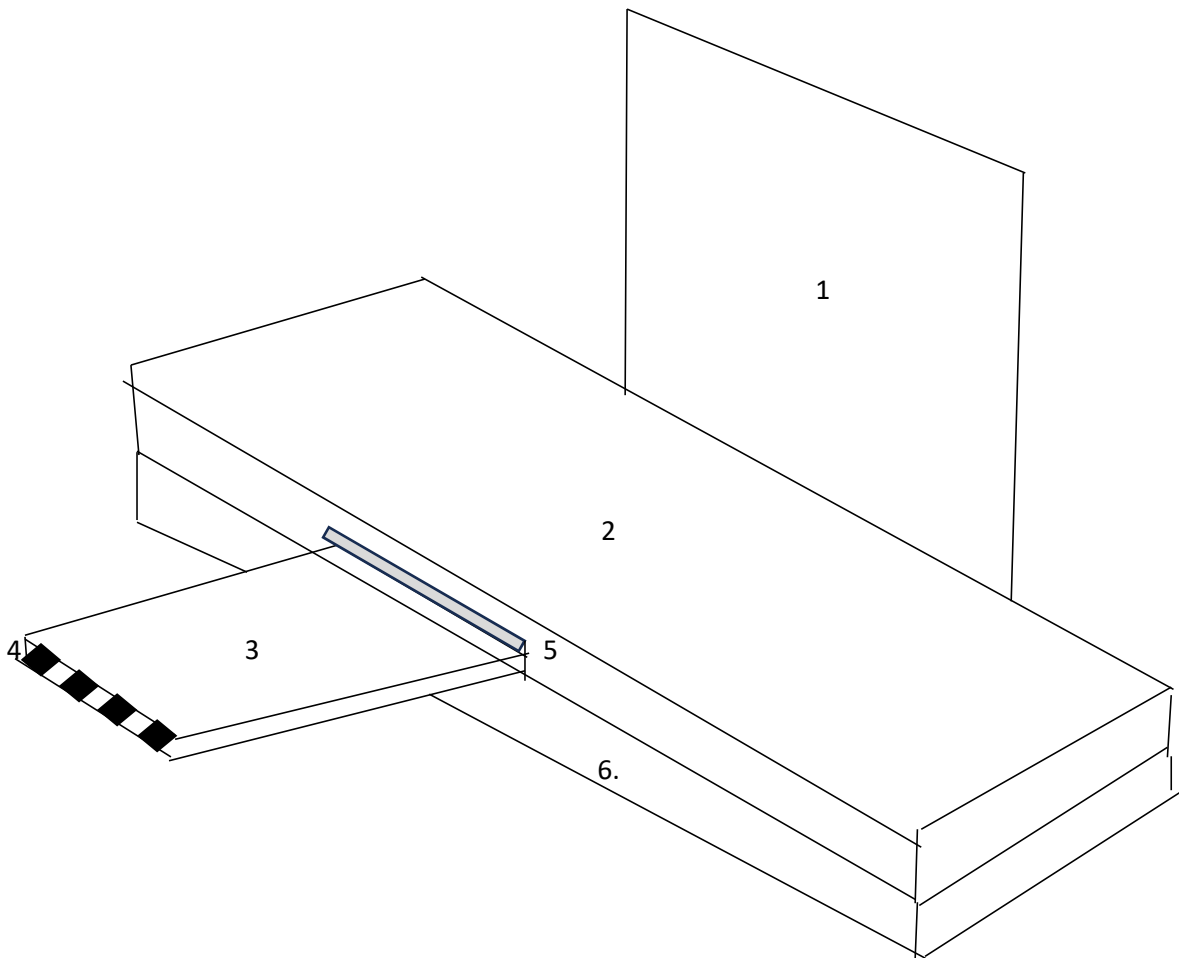

### Key

1. LARGER COMPUTER TFT
2. KEYBOARD
3. CAMERA MOBILE PHONE
4. CONTACT ASSEMBLIES
5. EJECT AND INSERT MECHANISM
6. Tilt Built into the keyboard

**THE SINGLEX LCD MOBILE CAMERA PHONE CAMCORDER CASSETTE MECHANISM COMPUTER**

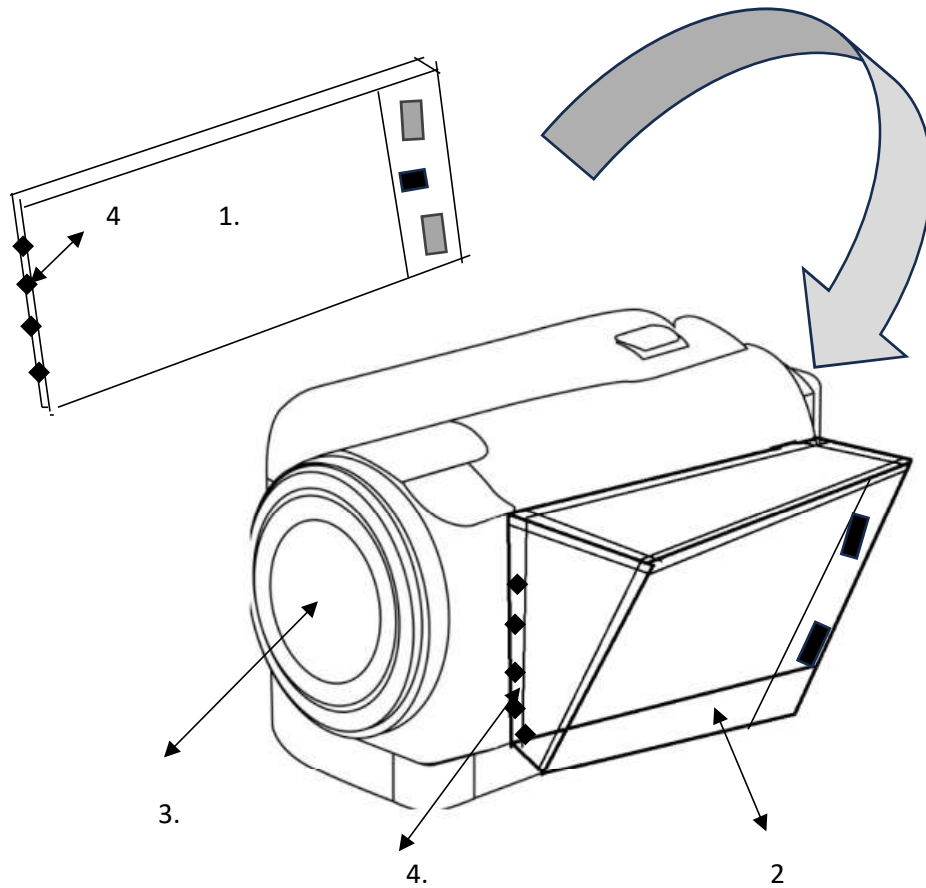

**KEY**

- 1. MOBILE CAMERA PHONE
- 2. CASSETTE DECK EJECT AND INSERT MECH FOR MOBILE CAMERA PHONE
- 3. CAMCORDER
- 4. COMPUTER CONTACT ASSEMBLIES



TEN FLASH UNIT PAD MOBILE CAMERA PHONE COMPUTER KEYABORD CASSETTE DECK

REAR OF COMPUTER PAD WITH TEN FLASH UNITS (REVERSE OFF)

PRINCIPLE OF COMPUTER CAMERA MOBILE PAD (A)

Here we have a *computer pad with ten flash unis* and one single lens unit on the top of the pad. With a built in mouse button on the bottom of the computer right/left button/dial assy /and rollerball mouse respectively. The dimensions will be outlined later but is similar to size of larger tft screen.

(A)

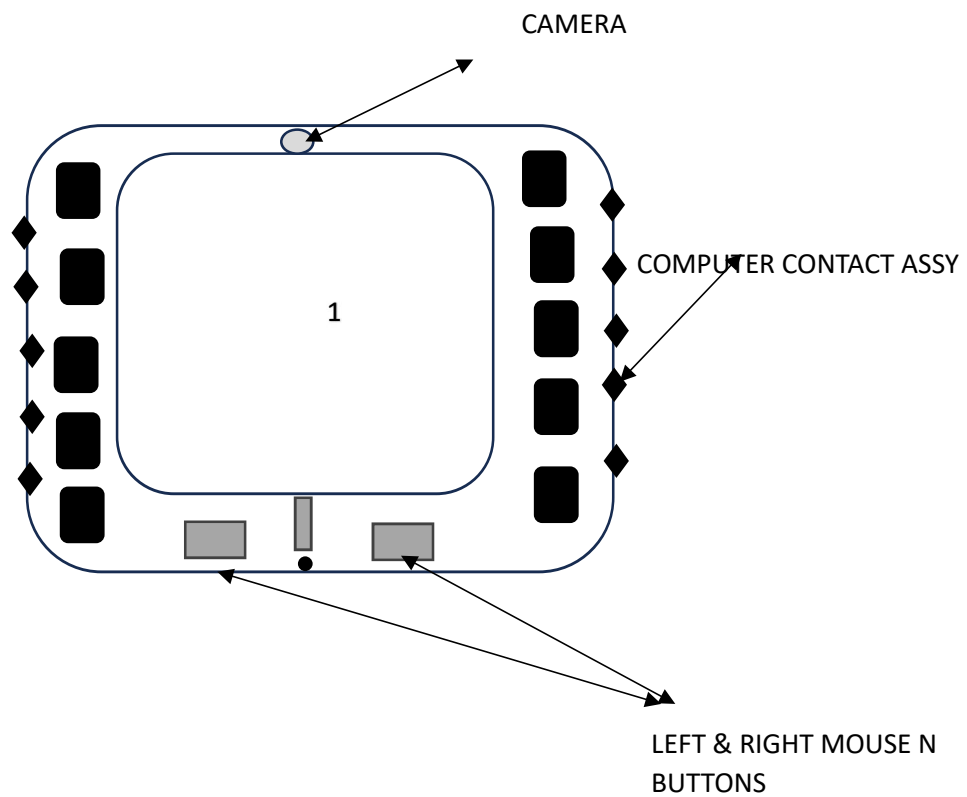

Principle B -Turning the Computer Pad into a new type Computer PAD SLR Big Camera Cassete Mech Deck.

Here The Initial Pad (A) is inserted to the cassette deck mech of the camera SLR Principle (B) Allowance of Functional Digital Infinity Camera.



(A)

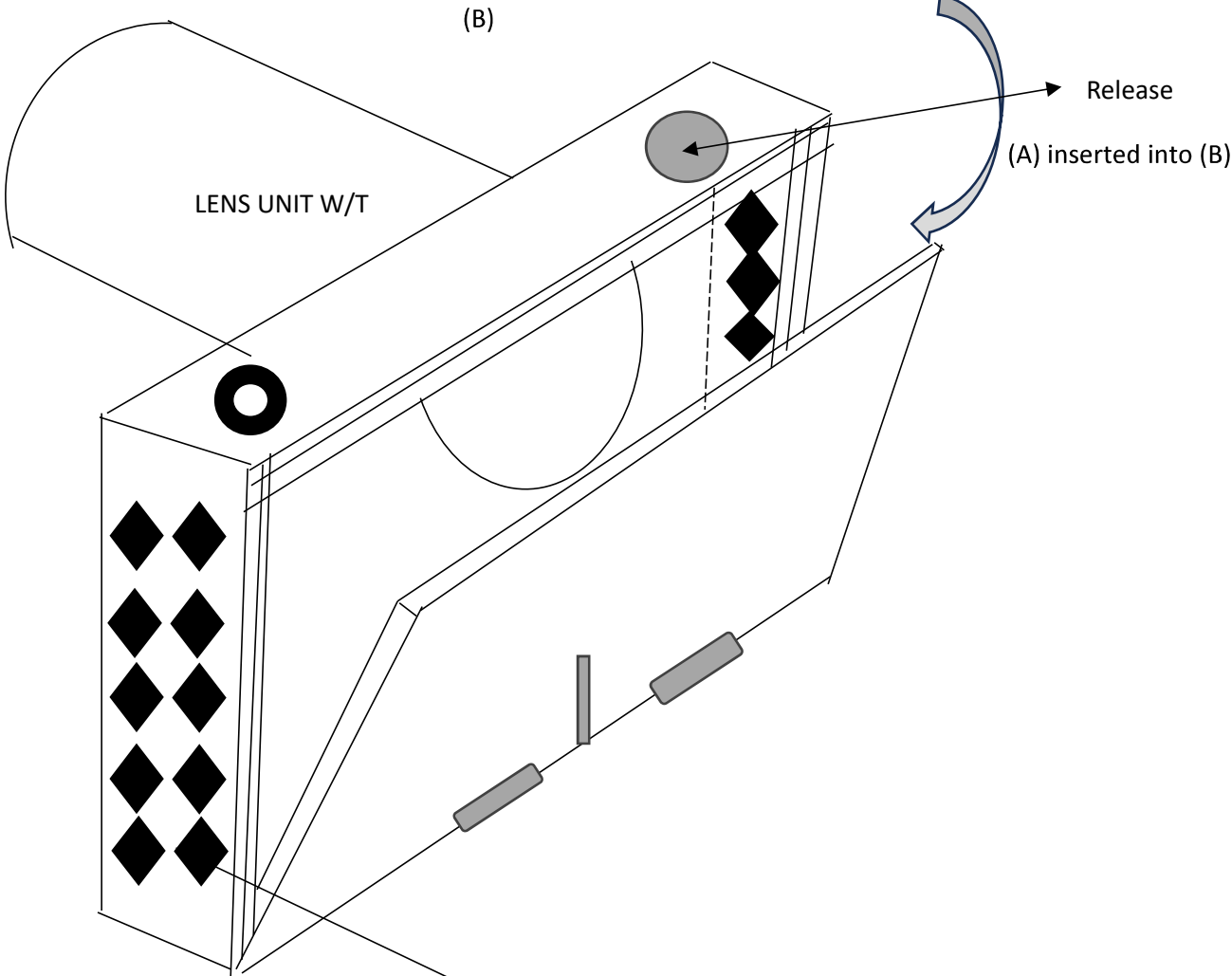

(B)

LENS UNIT W/T

Release

(A) inserted into (B)

Dual Computer Contact Assembly for Effective Communication.

### Principle (C) The New Type Major Computer Camera Mobile Pad Cassettes Deck

This principal B removes the lens detachable lens unit and then is docked in to the keyboard to allow the use of a computer via the larger TFT as discussed previously. The Operating in the Pad becomes what you see what you get twice with double cursor on the top of the largest TFT Screen. This is then computed and saved directly on the computer pad (A) and is interactable.

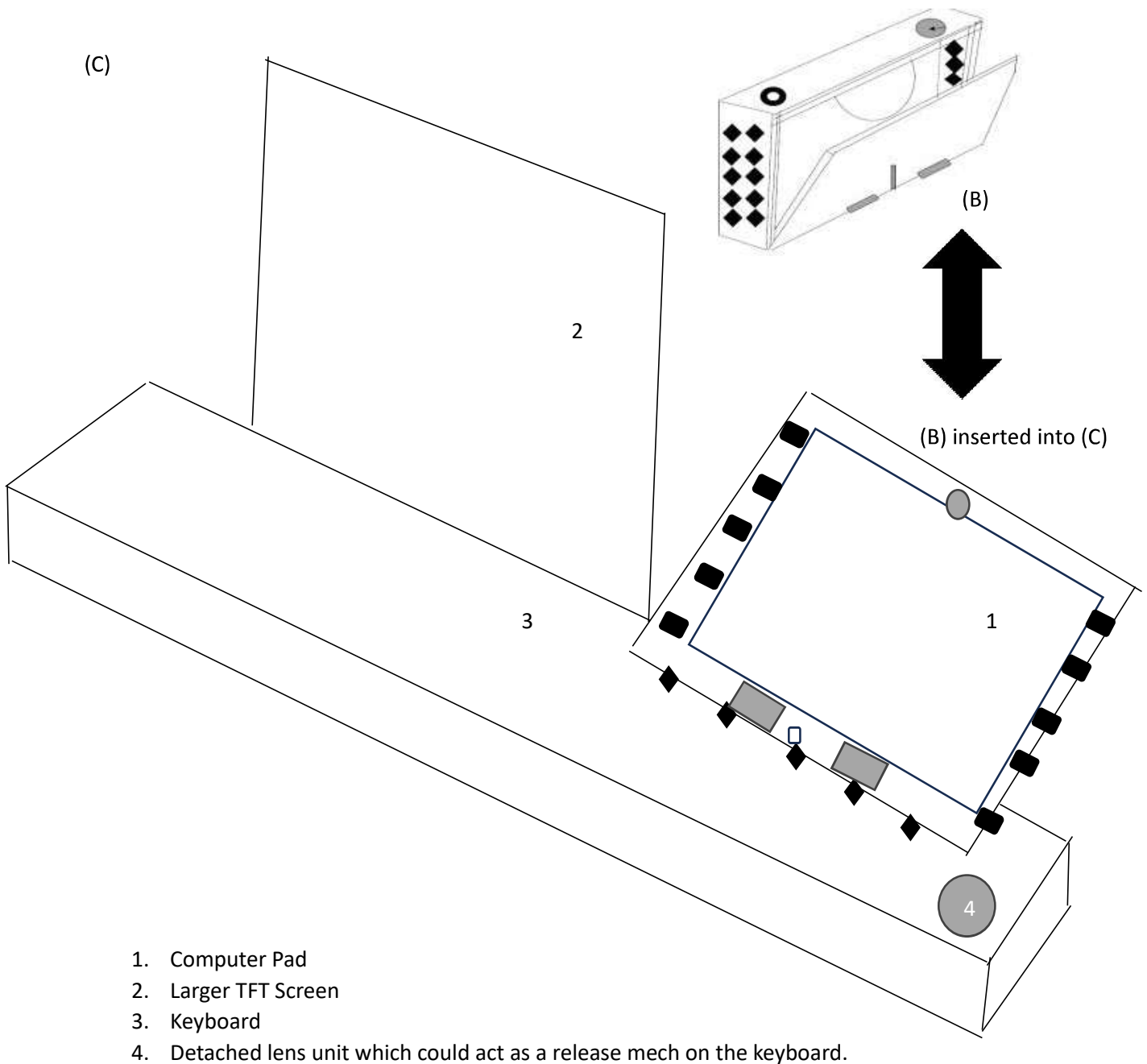

# HI-FI MOBILE CAMERA PAD COMPTON CASSETTE DECK DRIVE SYSTEM

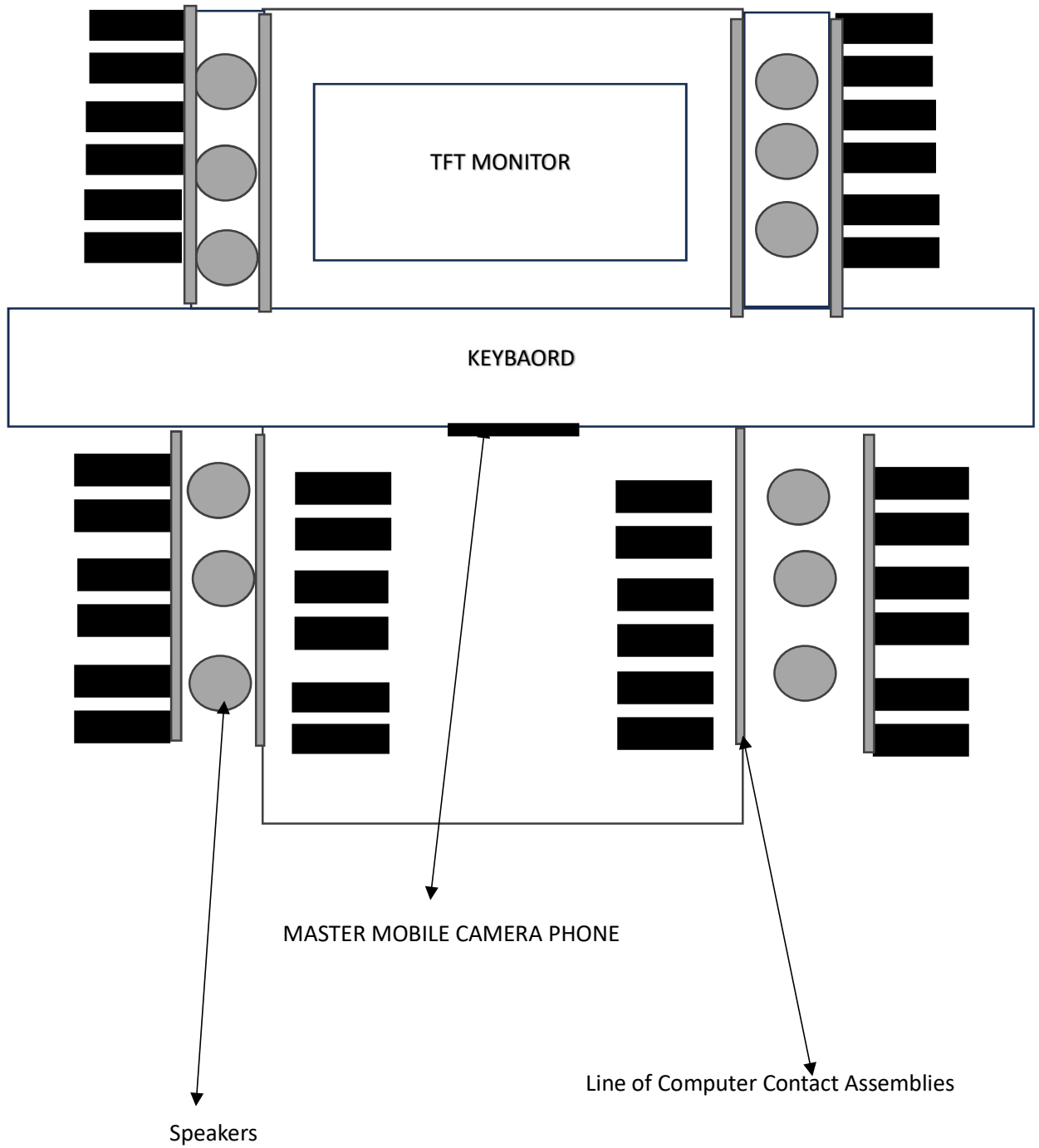

Computer Mobile Camera Pad Drives Cassette Mech System's n= 36 users

**THE NEWLY SET INTRANET ATM**

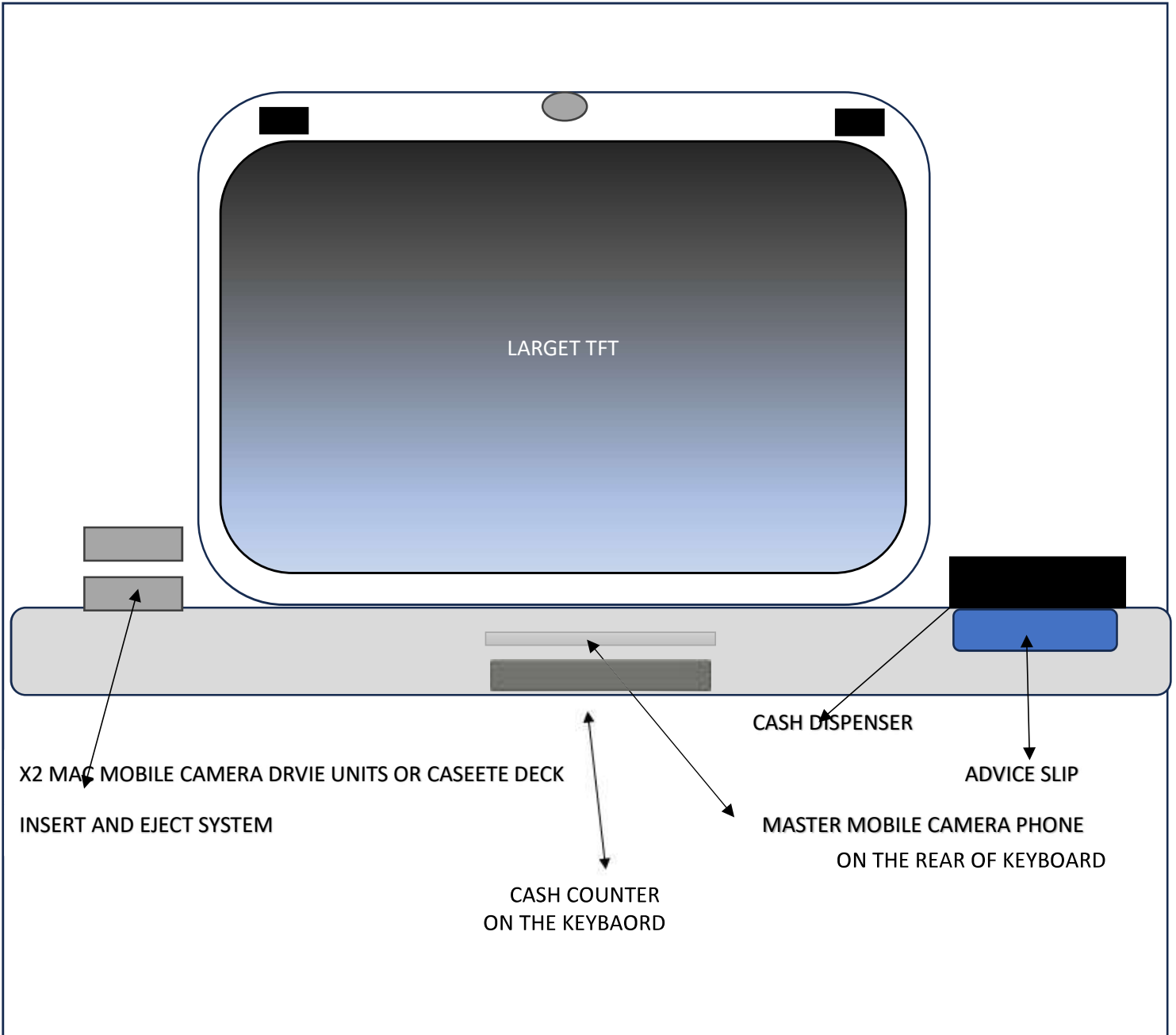

**NEWTYPE OF COMPUTER MOBILE PHONES (3 WAY FOLDABLE COMPUTER PHONE)**

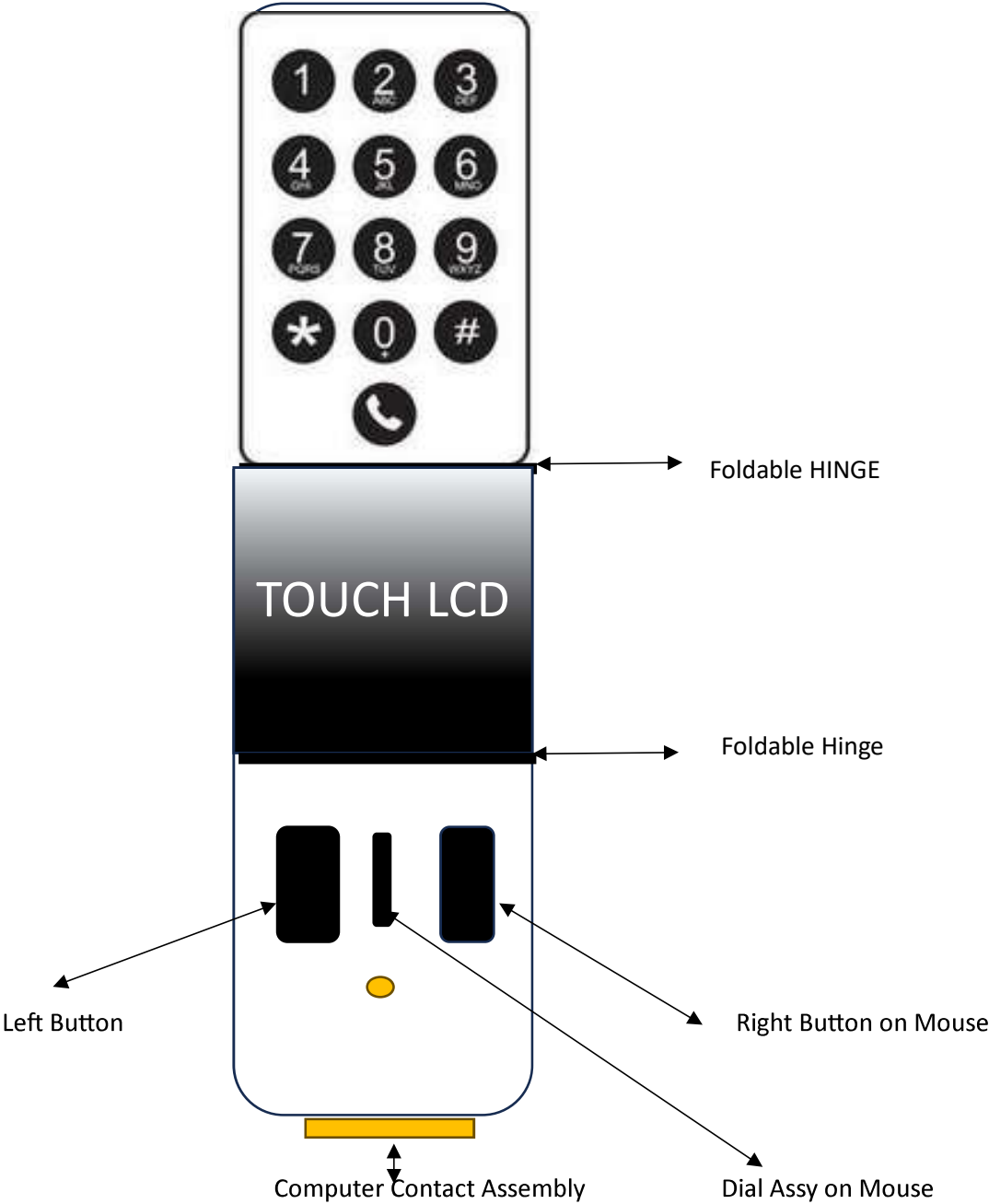

*Budget End Super Computer Phone*

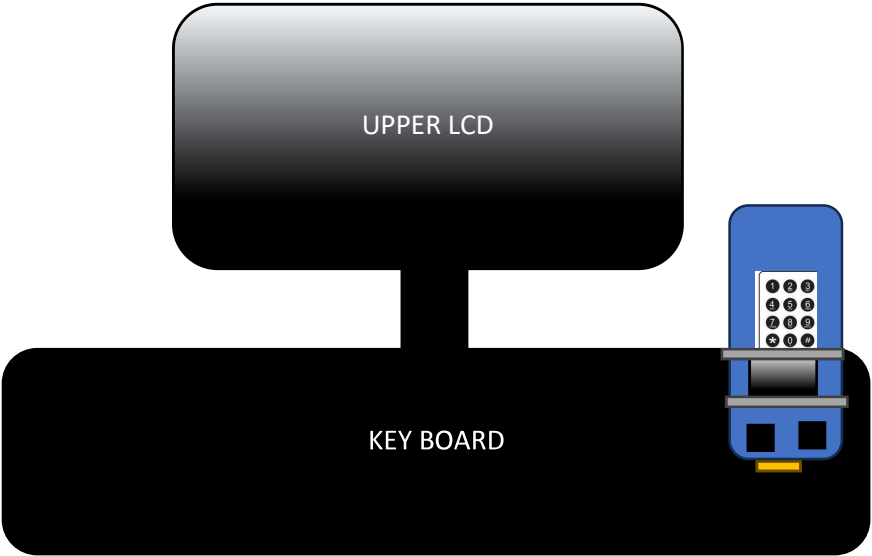

# STANDING UP COMPUTER (SUC) OR EVEN CASHLESS TILL

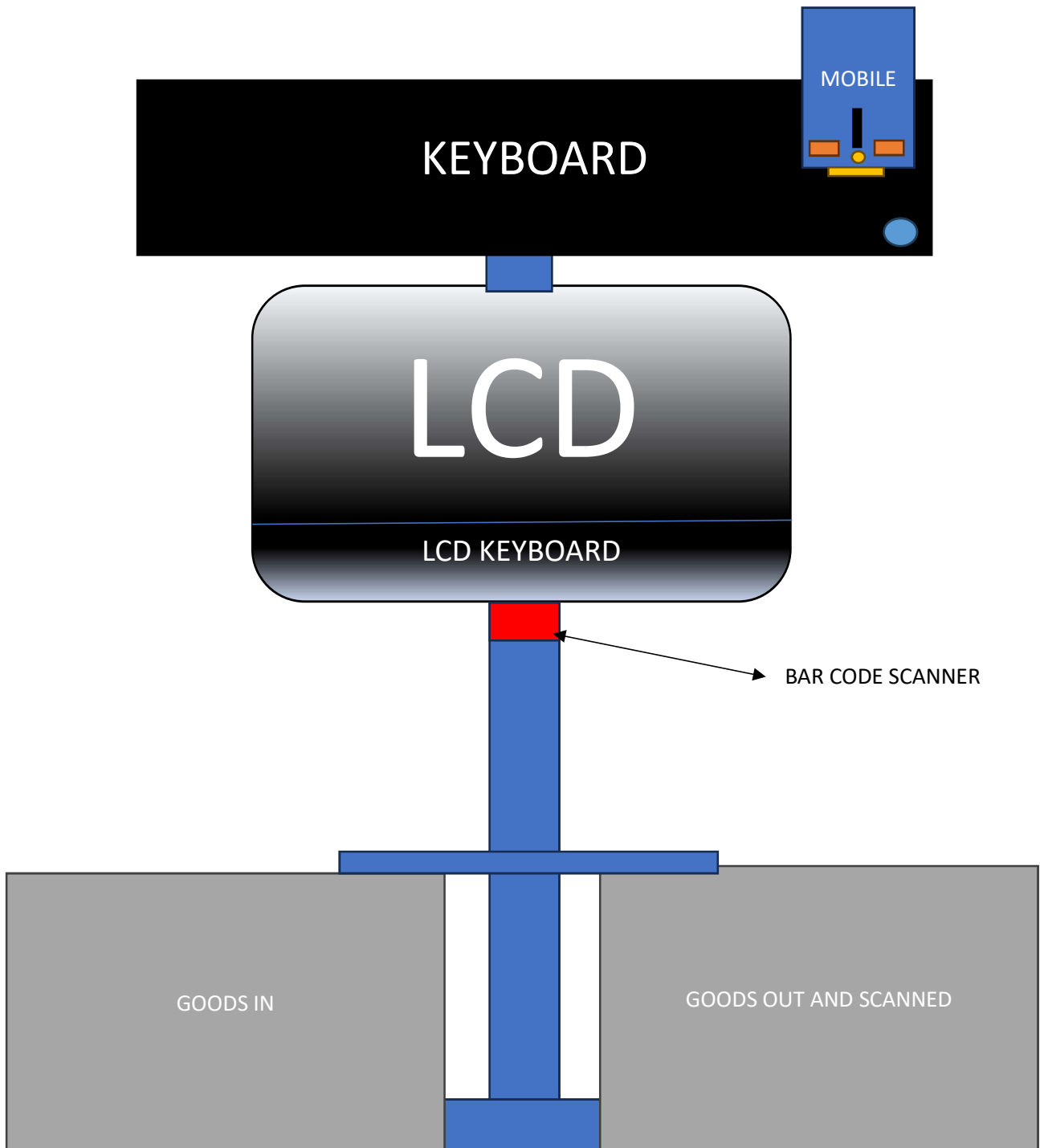



If one horizontal long row on contact assembly on the base of the camera phone does not work, then may be a row of two or more contact assemblies can be used to transfer data.

I.e. Transfer data from the camera mobile phone LCD Display to the Upper TFT Screen via Flexible Cables/Printed Circuit via the hinge and display what you see is what you get twice by using the mobile phone as the operating system.

This has no Personal Computer no CPU and No Lap Top and Separate Land Line Phone, it's all built in. This is effectively a new concept type of powerful computer using one or more database gadgets like a camera mobile phone. This can be forecasted to control Global Money Supply via New ATM Computer Systems.

Even Banks don't use this type of machine, it very novel and interesting to say the least.

TOP of Camera Mobile Phone

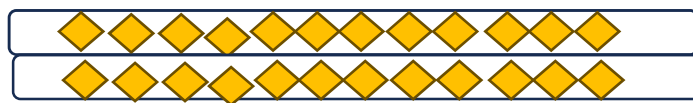

Bottom of Camera Mobile Phone.

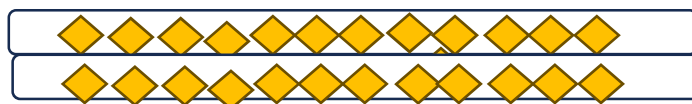

X 4 Good Computer Contact Assembly Connectivity.

## **Principle 1**

Conversely when embedding the camera mobile phone into the keyboard a cassette drive player mechanism can be such like built in to the keyboard. The Sony automatic eject mechanism is too noisy and colossal, keep it simple by having a simple cassette player holder like system. With one eject button on the keyboard.

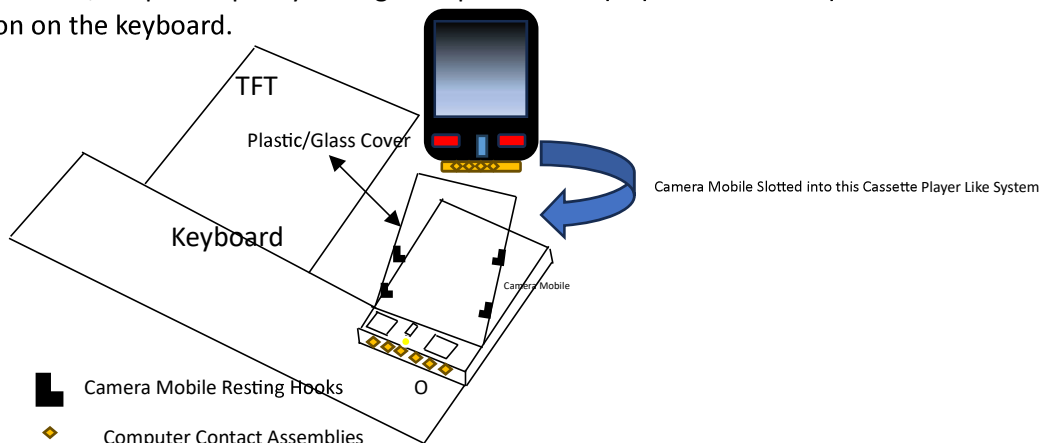

- Camera Mobile Resting Hooks
- ◆ Computer Contact Assemblies

- Camera Mobile Release Mech from the cassette like player which is now a mobile player system.

## Principle 2

Below is another way to slot the camera mobile phone in to the keyboard. From the Top of the camera mobile camera in to the slot leaving the left and right mouse button and multicontrol joy stick with mouse dial - exposed to manipulate with the TFT via keyboard. There will be a plastic glass cover Infront of the mobile, which then releases hand pressured downwards. In principle 2 it is suggested the computer contact assemblies are on top of the mobile camera phone. (This is the perverse design)

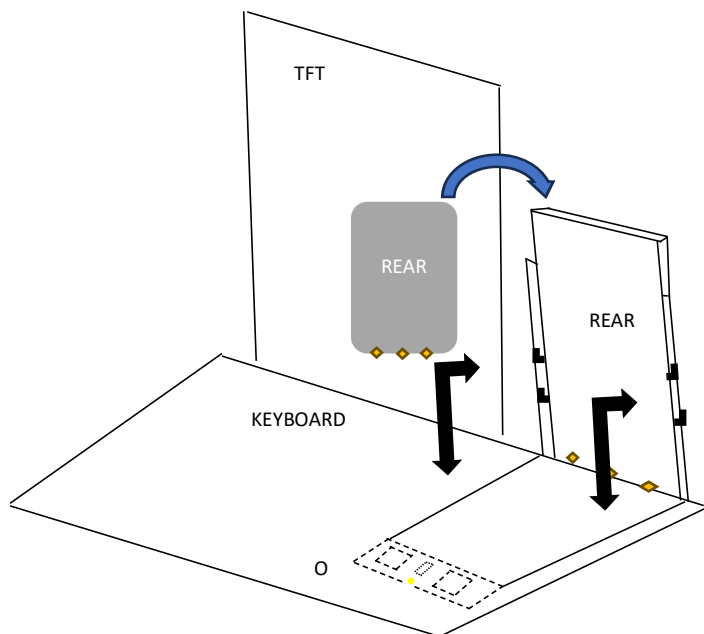

This is an alternative design to the hand set with a single horizontal row at **the top** of the camera mobile phone with the speaker.



This will use Principle 2 Design- Cassette Plater Drive Mechanism to insert the mobile camera phone from the Top in to the slot and push downwards, exposing the mouse keys.

This is more effective as its like a Master Card or Visa Card Being slotted into the ATM from vertically top to bottom sides.

Well it might be more permissible to locate computer contact assemblies on top and bottom to match the above principle 1 and 2 designs whilst in factory mode.

This is a sample Vertical Camera Mobile Phone with Top and Bottom Computer Contact Assemblies to use both principal designs 1 & 2, of slotting the device in to the keyboard.



Computer Contact Assemblies (CCA)

PRINCIPLE 3 -THE CAMERA

This can also be horizontal compact cameras, if you want to remove the usb cable /top cover, and even battery and charger then you for the following applies:

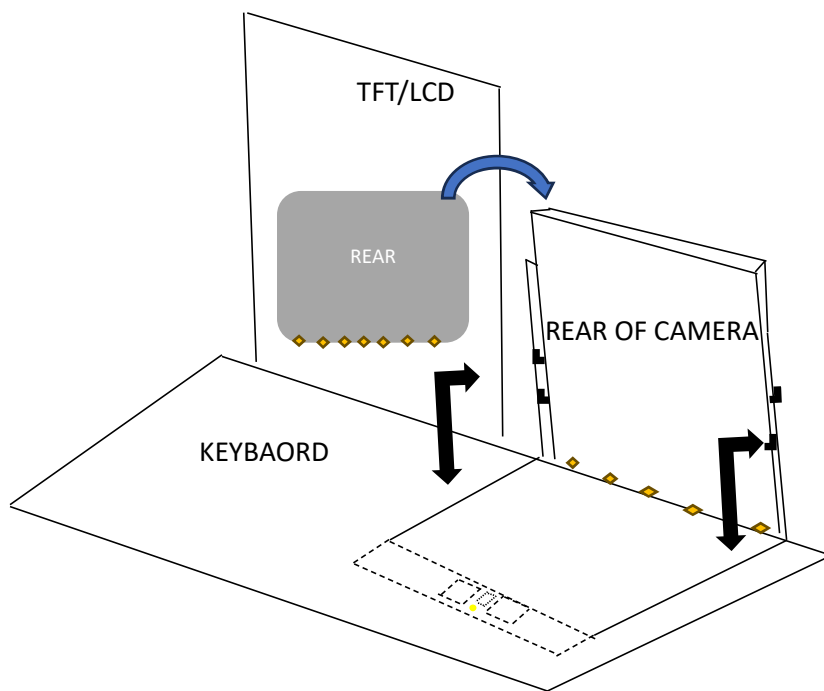
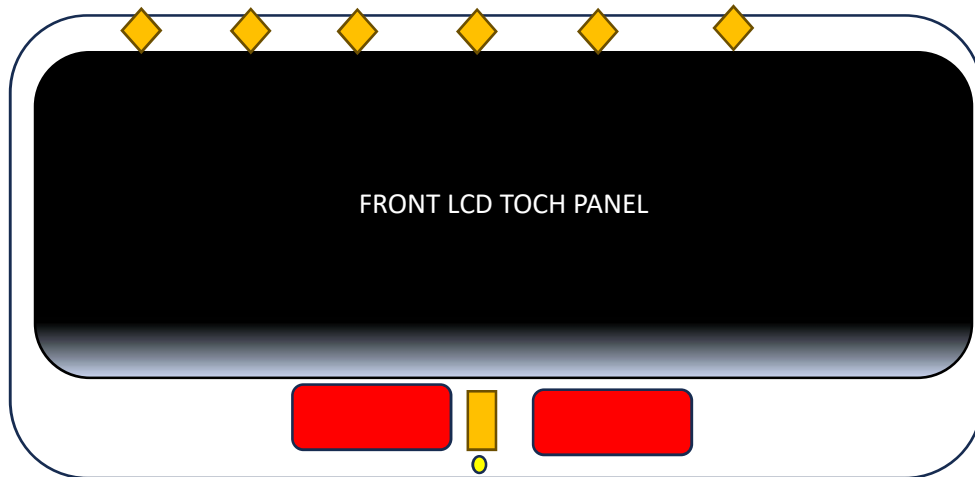

Just need to add measurements to the above design. There will be a flat optics on the front (NO LENSES). Touch panel on the rear and Solar Panel Rear with motion detection built in.